

TABLE OF CONTENTS

TABLE OF CONTENTS

Lesson 1: 105-mm Weapons Using Semi fixed Ammunition

105-mm M102 Towed Howitzer

105-mm M119 Towed Howitzer

Ammunition/Components for the 105-mm Howitzer

Preparation for Firing

Maintenance

Misfire Safety Procedures

Summary

Lesson 2: 155-mm Weapons Using Separate-Loading Ammunition

Introduction

155-mm M198 Towed Howitzer

155-mm M109A5/A6 Self-Propelled Howitzers

Ammunition/Components for the 155-mm Howitzer

Preparation for Firing

Maintenance

Misfire Safety Procedures

Summary

Examination

**CANNON CREW MEMBER
MOS 13B SKILL LEVELS 1 THROUGH 4**

**FIELD ARTILLERY AMMUNITION III
EDITION A
REVIEWED: OCTOBER 2004**

Six Credit Hours

GENERAL

This subcourse is designed to train the skills necessary for performing tasks related to the preparation of artillery projectiles for firing. This subcourse is presented in three lessons corresponding to a terminal objective supporting the following soldier's manual tasks:

LESSON 1: 105-mm Weapons Using Semifixed Ammunition

TASK NO: 061-266-1508

TASK: Prepare ammunition for firing.

CONDITIONS: You will be given an applicable fuze wrench, fuze setters, night lighting devices, section hand tools, an assistant to aid in moving the ammunition, a fire mission, protective covering (tarp or ammunition vehicle), and semifixed ammunition.

STANDARDS: You will be given an applicable fuze wrench, fuze setters, night lighting devices, section hand tools, an assistant to aid in moving the ammunition, a fire mission, protective covering (tarp or ammunition vehicle), and semifixed ammunition.

TASK NO: 061-268-1507

TASK: Load and fire a prepared round (M102).

CONDITIONS: You will be given an M102 howitzer, a prepared round, one assistant, and a fire command.

STANDARDS: Upon command, load and fire the howitzer.

TASK NO: 061-281-1543

TASK: Load and fire a prepared round (M119).

CONDITIONS: You will be given an M119 howitzer, a prepared round, one assistant, and a fire command.

STANDARDS: Upon command, load and fire the howitzer.

LESSON 2: 155-mm Weapons Using Separate-Loading Ammunition

TASK NO: 061-266-1508

TASK: Prepare separate-loading ammunition for firing.

CONDITIONS: You will be given a howitzer, separate hand tools, fuze wrenches, fuze setters, protective covering (tarp or vehicle), a fire mission, and one assistant.

STANDARDS: Prepare separate-loading ammunition for firing.

TASK NO: 061-270-1507

TASK: Load and fire a prepared round. (M109A5/A6)

CONDITIONS: You will be given an M109-series howitzer, a prepared round, a swab, a bucket of water, and a fire command.

STANDARDS: Upon command, load and fire the howitzer IAW the performance measures.

TASK NO: 061-271-1507

TASK: Load and fire a prepared round. (M198)

CONDITIONS: You will be given an M198-series howitzer, a prepared round, a swab, a bucket of water, and a fire command.

STANDARDS: Upon command, load and fire the howitzer IAW the performance measures.

Lesson 1
105-MM WEAPONS USING SEMIFIXED AMMUNITION

OBJECTIVE

Upon completion of this lesson, you will be able to distinguish, list, and record certain characteristics and functioning capabilities of the M102 and M119 howitzers. In addition, you will be required to recall and list the different types of malfunctions and prescribed misfire procedures and know how to prepare, load, and fire the howitzer as well as select the ammunition and components used to fire the weapon.

REFERENCES:

This sub course is based on TM 43-0001-28 and other materials approved for US Army field artillery instruction; however, development and progress render the text continually subject to change. Therefore, base your examination answers on material presented in this subcourse rather than on individual or unit experience.

1. INTRODUCTION.

a. M102 description. The 105-mm towed light M102 howitzer consists of the 105-mm howitzer cannon and the 105-mm howitzer recoil mechanism mounted on the carriage (Figure 2). The weapon is traversed and elevated by hand wheels located on the sides of the carriage. A 6,400-mil traverse capability is provided as the carriage pivots around the center of a circular base by means of a roller located at the rear of the trail assembly (Figure 2). The weapon can be airlifted and may be towed at 35 miles per hour (mph) over hard-surfaced roads. The 105-mm M102 howitzer has a very low silhouette when in the firing position.

b. Cannon. The cannon tube is screwed into the breech ring and is mounted in the recoil sleigh assembly. The purpose of the cannon tube is to house the complete round of ammunition and direct the projectile when fired. It is rifled to rotate the projectile to aid in maintaining direction and to prevent tumbling in flight.

c. Carriage. The carriage consists of the box trail, the cradle, the suspension and wheel assemblies, and the traversing mechanism. It mounts the cannon and recoil mechanism and provides the means of transporting and emplacing the weapon.

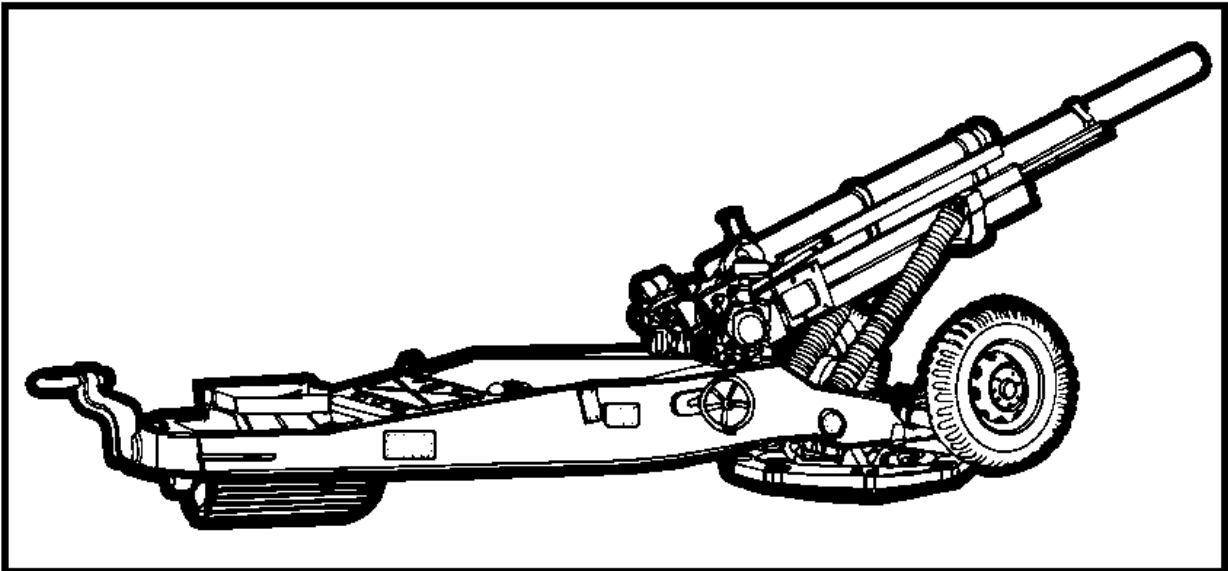

Figure 2. 105-mm M102 howitzer.

d. Tabulated data (M102 howitzer).

Muzzle velocity	494 meters per second
Maximum range	11,500 meters
Type breechblock	Vertical sliding wedge
Type firing mechanism	Spring-actuated inertia percussion
Maximum rate of fire	10 rounds per minute for the first 3 minutes
Sustained rate of fire	3 rounds per minute, thereafter

M119 105-mm light towed howitzer

The M119 is a light towed field artillery weapon system. It weighs 4520 pounds (including BII). The prime mover is the HMMWV (hum-vee) truck although a new 10,000-pound (gross weight) prime mover is in development. The M119 is air transportable with its basic load of ammunition by the UH-60 Black Hawk helicopter. Two of these weapons can be lifted at once by the CH-47 Chinook helicopter. It fires all conventional 105-mm ammunition out to a range of 14 km and with the M548 High Explosive Rocket Assisted (HERA) projectile, out to 15.1 km. This capability will be enhanced by the fielding of two ammunition projectiles: the XM913 HERA, giving the M119 a range of 19 km, and the XM915 Dual Purpose Improved Conventional Munitions (DPICM), giving it a range of 15 km.

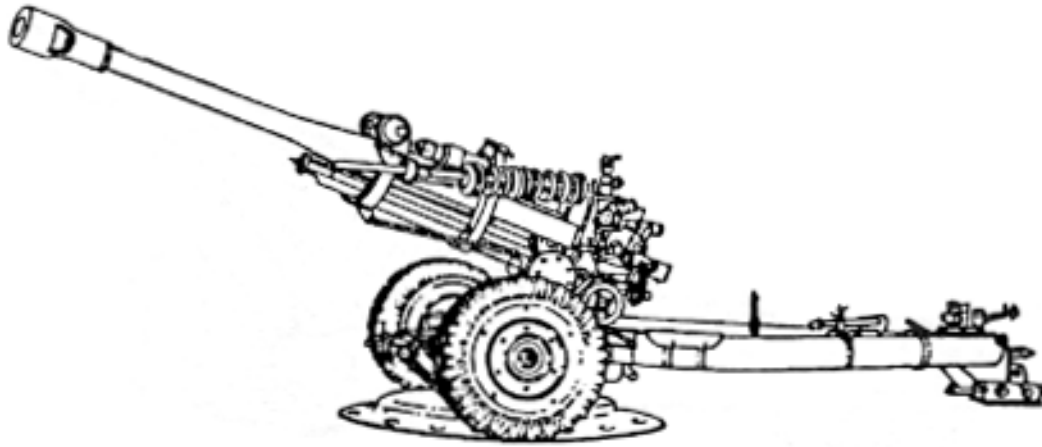

Figure 3 M119 light towed howitzer

TABULATED DATA (M119 HOWITZER)

- Muzzle velocity ----- (to be determined)
- Maximum range -----11,500 meters (charge 7), 14,000 meters (charge 8)
19,000 meters (RAP)
- Type breechblock -----Vertical sliding wedge
- Type firing mechanism -----Mechanically-activated percussion
- Maximum rate of fire -----6 rounds per minute for the first 2 minutes
- Sustained rate of fire -----3 rounds per minute for 30 minutes.

PRACTICE EXERCISE:

Complete the following exercises by circling T for true or F for false, circling the letter preceding the correct answer, or filling in the blanks, as appropriate. Be sure to complete the practice exercises as they appear. They are "building blocks" and will help you complete the rest of this subcourse successfully. The answers follow the last exercise and are separated by rows of slashes (///). If any of your answers are incorrect, restudy the appropriate part of the subcourse before you continue.

1. **T F** The sustained rate of fire for all 105-mm cannons is 4 rounds per minute.
2. **T F** The cannon tube is screwed into the breech ring and is mounted in the recoil sleigh assembly.
3. **T F F** The maximum rate of fire for the 105-mm howitzer is 10 rounds per minute for the first 3 minutes.

ANSWERS:

1. F 3 rounds per minute, thereafter
2. T
3. T

2. **AMMUNITION/COMPONENTS FOR THE 105-MM HOWITZER.** Ammunition for the 105-mm howitzers (M102 and M119) is classified as semifixed. The cartridge case is free fitted, rather than crimped, over the projectile base to make the propelling charges accessible for adjusting the number of increments (except the M622 high-explosive antitank (HEAT) round, which comes crimped to the cartridge case).

a. Complete round. A complete round of ammunition consists of all components required to fire the weapon once. These components consist of a primed cartridge case containing the propelling charge and a fuzed projectile. The round, with the cartridge case assembled over the projectile base, is loaded into the weapon as a unit.

b. Rounds available. The types of rounds available for the 105-mm howitzer cannons (M102 and M119A1/A2) are given in Table 1.

Table 1. Round type available for M101A1, M102 or M119 cannons.

MODEL	ABBREVIATION	TYPE	USE
XM 546 AND M546	APERS-T	FLECHETTE-LOADED, ALUMINUM PROJECTILE	ANTIPERSONNEL (EFFECTIVE IN DENSE FOLIAGE)
M1	HE	HIGH EXPLOSIVE-BURSTING	ANTIPERSONNEL, BLAST, MINING
M60	H/HD	BURSTING, CHEMICAL MUSTARD/DISTILLED MUSTARD	ANTIPERSONNEL, PERSISTENT
M360	GB	BURSTING, CHEMICAL-SARIN	ANTIPERSONNEL, NONPERSISTENT
M327	HEP/HEP-T	HIGH EXPLOSIVE, BURSTING/HIGH EXPLOSIVE, BURSTING, TRACER	DEFEAT ARMOR (EFFECTIVE AGAINST CONCRETE AND TIMBER TARGETS)
M622	HEAT	HIGH-EXPLOSIVE ANTITANK	DEFEAT ARMOR
M314-SERIES *	ILLUM	BASE-EJECTION PROJECTILE, PARACHUTE CANDLE	ILLUMINATION
M60A3	SMOKE WP	BURSTING CHEMICAL	SCREENING, SPOTTING, INCENDIARY
M84A1	SMOKE, HC	BASE-EJECTION PROJECTILE WITH CANISTERS FOR USE WITH FUZES M548 OR M565	SCREENING/TARGET IDENTIFICATION, SIGNALING
M84B1**	SMOKE, HC/ COLORED	BASE-EJECTION PROJECTILE WITH CANISTERS FOR USE WITH FUZES M501 ONLY	SCREENING/TARGET IDENTIFICATION, SIGNALING
M444	ICM	HIGH-EXPLOSIVE BOUNDING GRENADES	ANTIPERSONNEL
M67	TP-T	INERT PROJECTILE/INERT PROJECTILE WITH TRACER	TRAINING
M14	DUMMY	COMPLETELY INERT ROUND	TRAINING
*M314A3 IS INTENDED FOR USE AS A SIGNALLING DEVICE OR FOR ILLUMINATING A DESIGNATED AREA.			
**M84B1 IS USED AS A LEAFLET PROJECTILE.			

TABLE 1

Round type for M102 and M119A1/A2 cannons

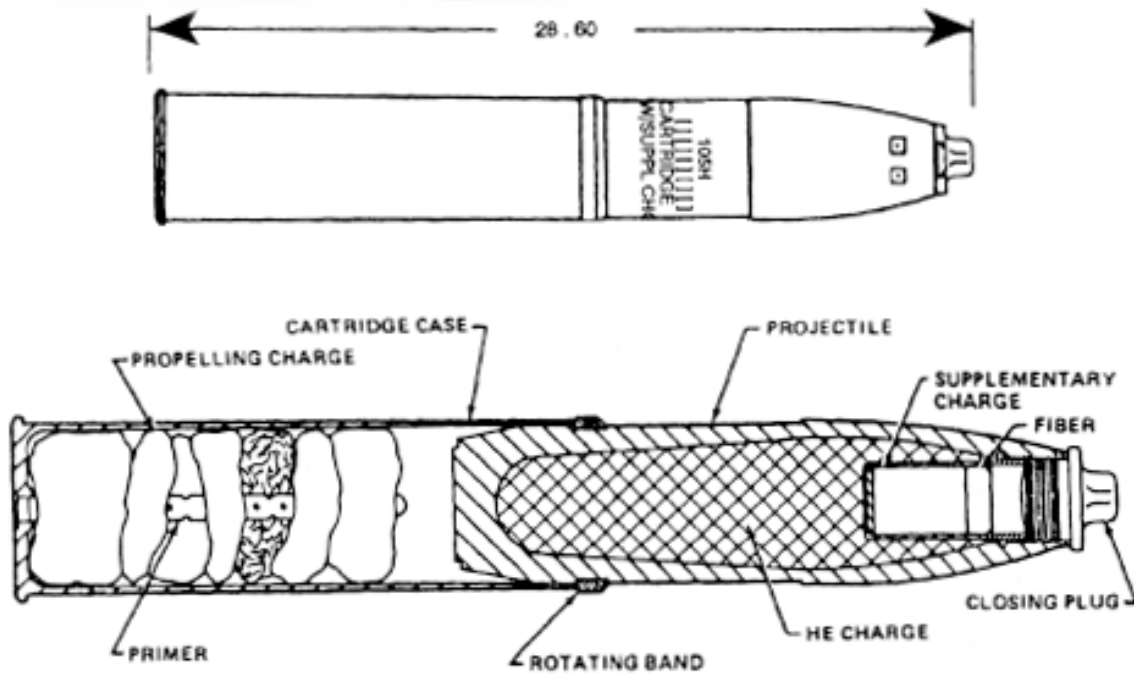

Figure 4 105-mm HE round, MI

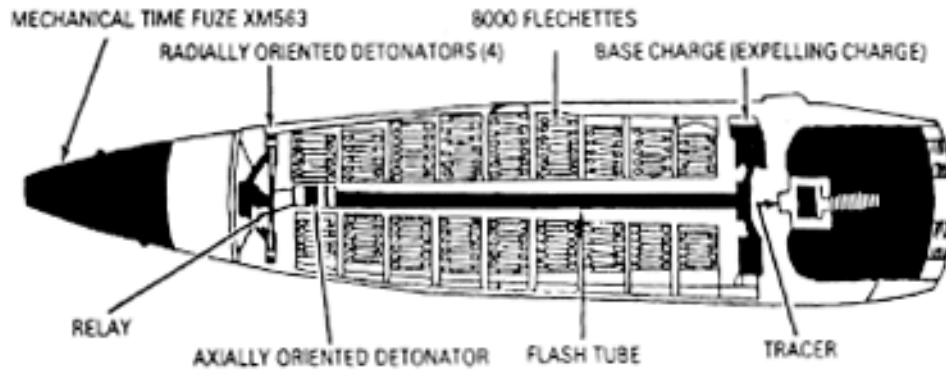

Figure 5 APERS fletcher (Beehive) projectile

WARNING

FIRING BEHIVE ROUNDS OVER THE HEADS OF EXPOSED FRIENDLY TROOPS IS PROHIBITED.

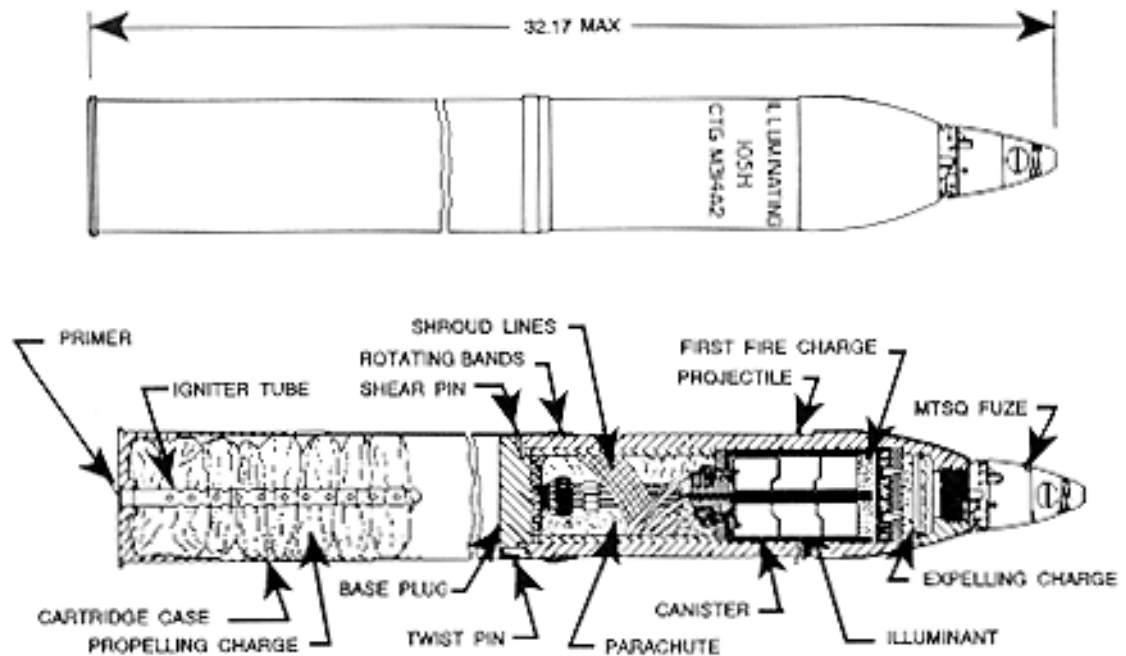

Figure 6 Illuminating projectile

Smoke round.
 Smoke rounds are available for 105-mm and 155-mm howitzers only, and are used for spotting, screening, and signaling purposes. For illustration purposes, a 155-mm smoke projectile is shown in Figure 7.

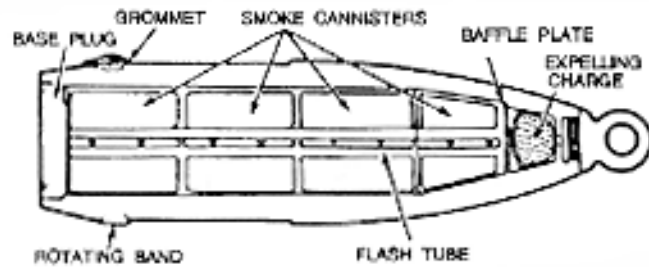

Figure 7 Smoke round

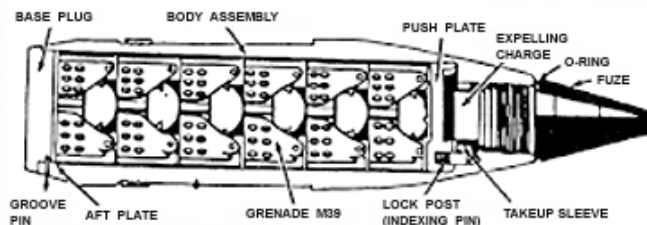

Figure 8 ICM projectile

Improved **conventional munitions rounds** (Figure 8). There are two types of ICM rounds available for field artillery howitzers: the old single-purpose antipersonnel round for the 105-mm, 155-mm, and the new dual-purpose, Antipersonnel-antimateriel round (dual purpose ICM or DPICM) for the 155-mm howitzers. **There are not antipersonnel-antimateriel rounds for the 105-mm howitzer.** The ICM (and DPICM) is designed to transport its internal payload of grenades to the target.

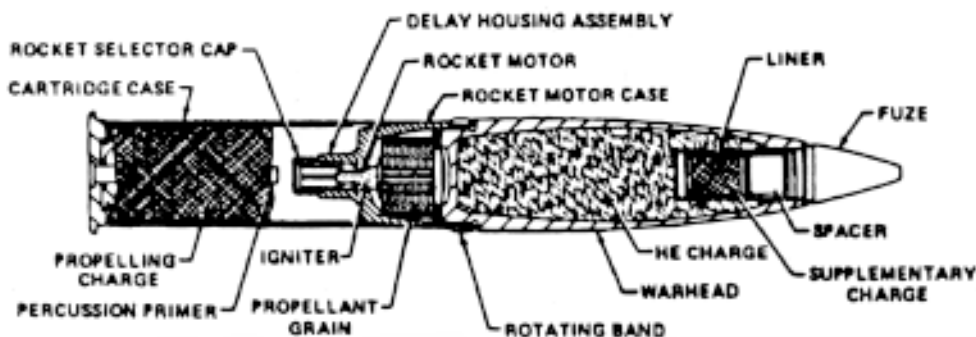
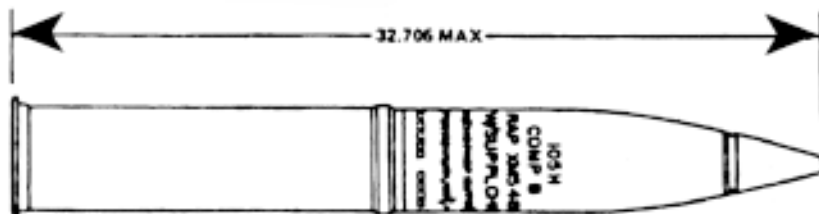

Figure 9 105-mm HERA, M548 round

c. Fuze available. Fuze types available for rounds fired from 105-mm howitzer cannons are given in Table 2.

Table 2. Fuze types available for rounds fired from 105-mm cannons.

FUZE	ABBREVIATION	MODE OF OPERATION	USE
POINT DETONATING	PD	POINT DETONATING	SQ FUNCTIONING ON IMPACT
POINT DETONATING	PD	POINT DETONATING	SQ OR DELAYED FUNCTIONING ON IMPACT
CONCRETE PIERCING	CP	POINT DETONATING, CONCRETE PIERCING	DELAYED FUNCTIONING ON IMPACT
MECHANICAL TIME	MT	MECHANICAL TIMER SET TO RELEASE FIRING PIN	AIRBURST
MECHANICAL TIME AND SUPERQUICK	MTSQ	MECHANICAL TIMER SET TO RELEASE FIRING PIN; W/PD, SQ ELEMENT	AIRBURST OR SQ FUNCTIONING ON IMPACT
TIME AND SUPERQUICK	TSQ	PYROTECHNIC TRAIN CONTROLS TIME OF FUZE INITIATION; W/PD, SQ ELEMENT	AIRBURST OR SQ FUNCTIONING ON IMPACT
PROXIMITY	PROX	ELECTRONICALLY CONTROLLED INITIATION; W/PD ELEMENT	FUNCTIONS ON APPROACH TO LAND OR WATER; SQ FUNCTIONING ON IMPACT

TABLE 2

d. Identification. Ammunition components and packing containers are identified by painting and marking. Complete rounds are identified by the color scheme and the marking.

(1) Model. A model designation, assigned to identify a particular design, is included in the marking. Model designations consist of M, XM, or T, and an Arabic numeral(s). Modifications are indicated by adding A or # and an Arabic numeral. M1A1, for example, indicates the first modification of an item for which the original designation was M1. XM409E5, as another example, indicates the fifth modification of an item originally designated XM409.

(2) Ammunition lot number. When ammunition is manufactured, an ammunition lot number, consisting of the manufacturer's symbol and a number, is assigned.

(3) Weight-zone marking. Projectiles are grouped into weight zones to minimize dispersion. Appropriate ballistic corrections, as shown in firing tables, may be applied. Weight zones are indicated on projectiles by means of one or more squares, with or without a triangle of the same color as the marking. Two squares indicate standard or normal weight (for the 105-mm) for which no weight corrections are needed when computing firing data.

(4) Painting. Artillery projectiles are painted to prevent rust and to provide a ready means of identification. Two systems of color coding are in existence. The color codes used are given in Table 3.

e. Authorized rounds. Only authorized projectiles will be used in this weapon. Projectile-fuze combinations for authorized rounds are given in Figure 3. Projectiles of current manufacture, which have deep fuze cavities and supplementary charges of TNT, are suitable for use with the long intrusion proximity (variable time [VT]) fuzes. Deep-cavity projectiles are identified by W/SUPPL CHG marked on the projectile.

Table 3. Color coding of ammunition for the 105-mm cannons.

TYPE AND MODEL NUMBER OF PROJECTILE	NEW MANUFACTURE			OLD MANUFACTURE		
	COLOR OF PROJECTILE	NUMBER/COLOR OF BANDS	MARKING	COLOR OF PROJECTILE	NUMBER/COLOR OF BANDS	MARKING
ASPERS-T XM546* AND M546*	OLIVE DRAB	1/YELLOW	WHITE (WHITE DIAMONDS INDICATE FLECHETTES)	NA	NA	NA
DUMMY, M14	UNPAINTED OR BRONZE	NONE	WHITE	BLACK OR BLUE	NONE	WHITE
GAS (H, HD), M60	GRAY	2/GREEN 1/YELLOW	GREEN	GRAY	2/GREEN	GREEN
GAS (GB), WITH BURSTER, M360	GRAY	3/GREEN 1/YELLOW	GREEN	GRAY	2/GREEN	GREEN
GAS (GB), WITHOUT BURSTER, M360	GRAY	3/GREEN	GREEN	GRAY	2/GREEN	GREEN
M413 OR M444 ICM	OLIVE DRAB	NONE**	YELLOW	NA	NA	NA
HE, M1	OLIVE DRAB	NONE	YELLOW	OLIVE DRAB	NONE	YELLOW
HEP, M327	OLIVE DRAB	1/BLACK	YELLOW	OLIVE DRAB	NONE	YELLOW
HEAT, M622	OLIVE DRAB	NONE	YELLOW	BLACK	NONE	YELLOW
ILLUMINATING, M314 SERIES	WHITE	NONE	BLACK	GRAY	1/WHITE	WHITE
TARGET PRACTICE, M67	BLUE	NONE	WHITE	BLUE	NONE	WHITE
SMOKE (HC AND COLOR), M84 SERIES	LIGHT GREEN	NONE	BLACK	GRAY	1/YELLOW	YELLOW
SMOKE (WP), M60A3	LIGHT GREEN	1/YELLOW	LIGHT RED	GRAY	1/YELLOW	YELLOW
*THE XM546 APERS (BEEHIVE) ROUND WILL NOT BE FIRED OVER THE HEADS OF FRIENDLY TROOPS THE M546 HAS NO SUCH RESTRICTIONS.						
**INDICATES A ROW OF YELLOW DIAMONDS AROUND THE OGIVE OF THE PROJECTILE						

TABLE 3

PRACTICE EXERCISE:

4. Ammunition for the 105-mm howitzer is classified as _____.
5. A complete round of semifixed ammunition components consists of a primed cartridge case containing the propelling charge and a _____.
6. Complete rounds are identified by the color scheme and the _____.
7. Weight zones are indicated on projectiles by means of one or more _____.

ANSWERS:

4. Semifixed.
5. Fuzed projectile.
6. Markings.
7. Squares.

3. PREPARATION FOR FIRING. Most rounds for the 105-mm howitzer cannons require preparation of projectile, propelling charge, and fuze.

- a. Identification. Typical markings for 105-mm howitzer rounds are shown in Figure 9.

(SEE NOTE 1) TYPE AND MODEL NUMBER OF PROJECTILE	PD		MT	MTSQ			BD	VT						
	M78, CP SERIES	M557	M739	M563 SERIES	M565	M501 SERIES	M577	M548	M564/M582	M62, M62A1	M91 SERIES	M513 SERIES	M728	M732
APERS-T, XM546 (NOTE 2) OR M546				X										
GAS, (H OR HD), (NOTE 3) M60		X	X						X					
GAS, GB, M360 (NOTE 3)		X	X											
HE, M1 (NORMAL CAVITY)	X	X	X						X					X
HE, M1 (DEEP CAVITY) (NOTE 4)	X	X	X						X			P	P	X
HE, M444					X									
HEP/HEP-T, M327									X	(X)				
ILLUM, M314 (OLD SERIES)						X								
ILLUM, M314A3 (NEW SERIES)					X		X	X						
SMOKE, BE, M84 (OLD SERIES)						X								
SMOKE, HC M84A1 (NEW SERIES)					X		X	X						
SMOKE, WP, M60A3		X	X						X					
TP, M67										X				
TP-T, M67											X			

X—AS ISSUED OR COMPATIBLE
P—REQUIRES REMOVAL OF SUPPLEMENTARY CHARGE IF PRESENT
NOTE 1: ALL PROJECTILES ARE ISSUED WITH A FUZE INSTALLED EXCEPT THE HIGH EXPLOSIVE PROJECTILE AND SOME LOTS OF THE WP ROUND.
NOTE 2: XM546 (BEEHIVE) ROUND IS NOT TO BE FIRED OVER THE HEADS OF FRIENDLY TROOPS. NO RESTRICTIONS ON THE M546.
NOTE 3: SOME GAS PROJECTILES MAY COME WITH THE M508 IMPACT FUZE.
NOTE 4: USE DESENSITIZING CAP XM5 ONLY ON THE M513-SERIES PROXIMITY FUZES.

Authorized ammunition and projectile-fuze combinations
for the 105-mm cannons.

TABLE 4

a. Unpacking. Retain packing materials for repackaging, as required.

(1) Rounds are packed in individual fiber containers. Outer packing consists of a wooden box, metal containers, or a crate.

(2) All 105-mm rounds are issued complete with fuzes already assembled to the projectile and packed inverted in the fiber containers except HE, HE rocket assisted (RA), and some lots of white phosphorous (WP) rounds. Separate fuzes will have to be requisitioned for those rounds. These fuzes will come eight to a sealed metal container with two metal containers in a wooden, wire-bound box.

b. Marking of packaging. Markings on outer and inner packs are given in Table 4.

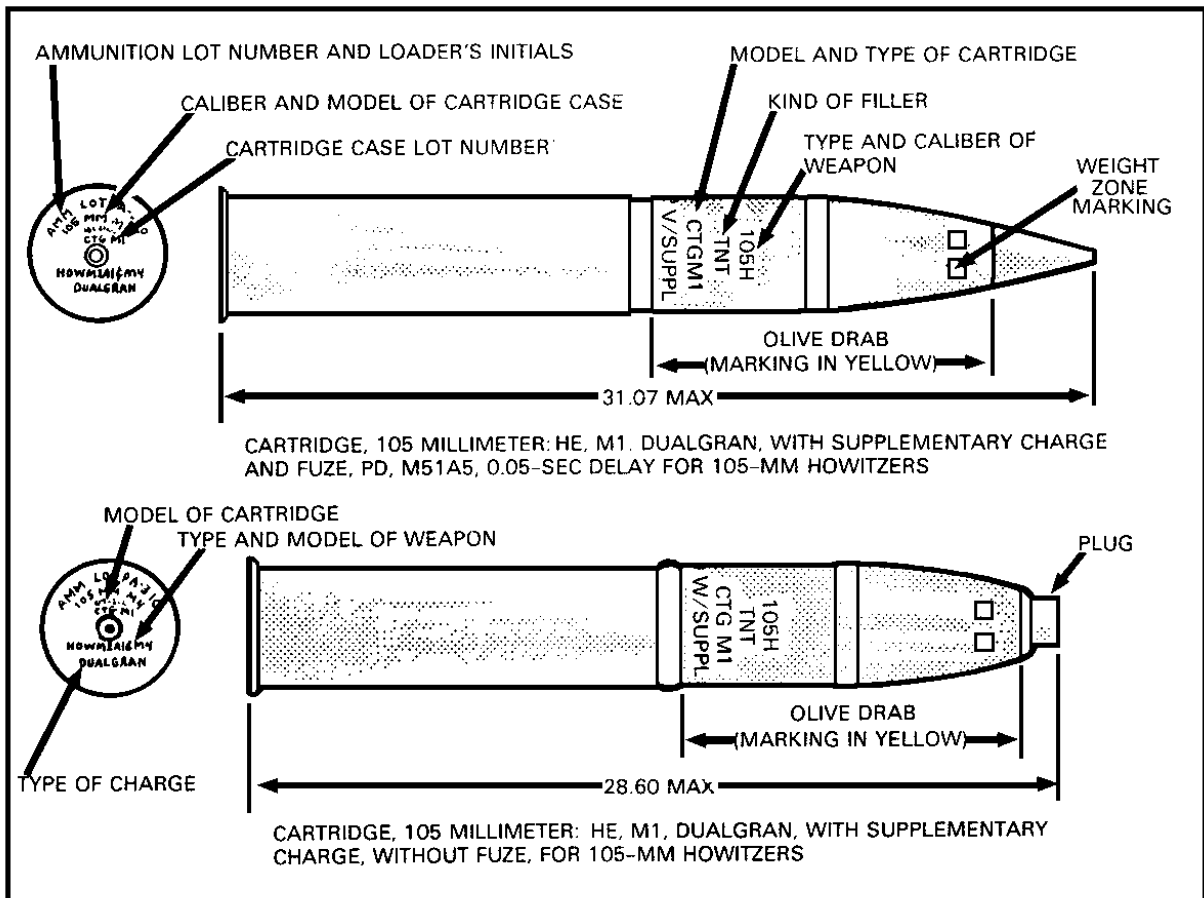

Figure 4. Typical markings of 105-mm HE cartridges.

c. Procedure. Following is the prescribed procedure for unpackaging projectiles:

- Examine ammunition box markings to determine identification.

CAUTION
DO NOT USE AXES, CROWBARS, OR OTHER IMPLEMENTS THAT MAY DAMAGE INNER PACK OR AMMUNITION.

- Open the outer pack, and remove the fiber containers.
- Open the fiber container, and remove the cartridge case and cartridge.
- Remove U-shaped packing stop.

CAUTION
SERIOUS DAMAGE MAY RESULT IF PACKING STOP IS NOT REMOVED BEFORE FIRING.

- Inspect the round. Ensure the nomenclature is correct. Check that the round is not damaged or corroded and is free of foreign matter.
- If necessary, remove foreign matter.

NOTE: Slight rust is not a cause for unserviceable.

- Do not use blank cartridges with loose or broken closing caps; report such items to the ammunition officer for disposal?
- Unpack the fuze, when separately issued, following the preceding steps as applicable.

d. Fuzing.

(1) Base-detonating fuzes. Base-detonating (BD) fuzes M62A1, M62, M91A1, or M91 do not require setting or other adjustment before firing. These fuzes are used with HEAT and high-explosive plastic (HEP) rounds.

(2) Fuze removal. Certain rounds are supplied fuzed. 105-mm HE rounds M1 and HE RA M548 may be shipped with fuzes, which must be removed if time or proximity (VT) fuze action is desired.

- Place the projectile upright with the base inside the fiber container cover.
- Using a screwdriver that fully fits the screw slot, loosen the booster setscrew in the nose of the projectile, when present.
- Insert the M18 fuze wrench in the wrench slots of the fuze. Taking care not to strike any part of the fuze, strike the wrench handle sharply in a counterclockwise direction. Loosen the fuze from the projectile; unscrew and remove the fuze and booster.
- Inspect the cavity and projectile threads for damage. Remove the loose material from the cavity. If any high explosive is found adhering to the threaded portion of the projectile throat, segregate the round for disposition by qualified ammunition personnel.

(3) Closing plugs removal.

- Place the projectile upright with the base inside the fiber container cover.
- Loosen the setscrew in the nose of the projectile, when present, using a screwdriver that fully fits the screw slot.
- Insert the M18 fuze wrench in the wrench slots of the plug; strike the wrench handle sharply in a counterclockwise direction.
- Remove the plug gasket and filler beneath the plug.
- Inspect the cavity and projectile threads for damage. Remove loose material from the cavity. If any high explosive is found adhering to the threaded portion of the projectile throat, segregate the round for disposition by qualified ammunition personnel.

(4) Supplementary charge. When preparing rounds for concrete-piercing (CP), point-detonating (PD), mechanical time (MT), mechanical time super quick (MTSQ), and short-intrusion proximity (VT) fuzes, inspect for the presence of supplementary charges.

WARNING
DO NOT FIRE ANY CAVITIZED ROUND WITHOUT A VT FUZE OR THE SUPPLEMENTAL CHARGE.

For VT firing with a long-intrusion fuze, remove the supplementary charge as follows:

- Remove the supplementary charge and felt pad by means of the lifting loop. If the charge cannot be removed by the lifting loop, fire with PD, MTSQ, or a short-intrusion VT fuze; or dispose of the round.

WARNING

DO NOT TRY TO REMOVE THE SUPPLEMENTARY CHARGE BY ANY MEANS OTHER THAN THE LIFTING LOOP. USE OF SCREWDRIVERS OR OTHER TOOLS TO REMOVE THE SUPPLEMENTAL CHARGE IS PROHIBITED.

- Inspect the cavity and projectile threads for damage. Remove loose material from the cavity. If any high explosive is found adhering to the threaded portion of the projectile throat, segregate the round for disposition by qualified ammunition personnel.

e. Fuze assembly.

(1) All fuzes, except CP. Screw in the fuze by hand. If binding occurs, inspect the fuze cavity and threads of both the fuze and projectile. Reject whichever is at fault.

WARNING

WHEN TIGHTENING A FUZE TO THE PROJECTILE, DO NOT HAMMER ON THE FUZE WRENCH. DO NOT USE AN EXTENSION HANDLE ON THE FUZE WRENCH OR STAKE (FORCE) THE FUZE TO THE PROJECTILE UNDER ANY CIRCUMSTANCES. SHOCKS TRANSMITTED TO FUZES DURING ASSEMBLY MAY INCREASE THE PERCENTAGE OF MALFUNCTIONS.

- Using the M18 fuze wrench, tighten the fuze to the projectile so that the fuze shoulder is seated flush with the nose of the projectile and the fuze leaves no gap.

WARNING

DO NOT FIRE A ROUND UNLESS THE FUZE IS FULLY SEATED. ROUNDS FIRED WITH IMPROPERLY SEATED FUZED MAY RESULT IN PREMATURE FUNCTIONING, CAUSING DEATH OR INJURY TO PERSONNEL WITH EXTENSIVE DAMAGE TO EQUIPMENT.

- If the projectile setscrew is present, tighten it to below the level of the contour of the projectile.

(2) CP fuzes M78 and M78A1. The booster is not issued assembled to the fuze and must be assembled to the projectile.

- Remove the safety pin, if present, from the M25 booster.
- Screw the booster into the booster cavity of the projectile. Tighten the booster, using the booster end of the M16 fuze wrench.
- Screw the CP fuze M78A1 (or M78) into the fuze cavity, and tighten it using the M16 fuze wrench. Make sure the fuze shoulder seats flush against the nose of the projectile. Do not stake the fuze to the projectile.

- If the projectile setscrew is present, tighten it to below the level of the contour of projectile.

f. Preparing charge.

CAUTION

UNDER NO CONDITIONS WILL THE FIXED CHARGES OF THE HEAT, HEAT-T, HIGH-EXPLOSIVE PLASTIC (HEP), HEP-T, AND TARGET PRACTICE WITH TRACER (TP-T) ROUNDS BE ALTERED. MAXIMUM PENETRATION OF ARMORED TARGETS IS SECURED WITH THE FIXED CHARGES FURNISHED.

(1) Cartridge case. Cartridges are assembled with the M14-series cartridge cases, which include the M14 (brass), M14B1 (steel), and M14B2 (5-piece, spiral-wrapped steel) cartridge cases. Blank cartridges are assembled with the M15 (brass) or M15B1 (steel) cartridge cases.

(2) Primer. Percussion primers are used with these cartridges and come as an integral part of the cartridge case.

(3) Propelling charge. Most 105-mm cartridges contain the M67 propelling charge, which contains zoned charges (seven increments) of M1 dual granulation propellant. (Some of these propelling charges are of older manufacture and are made with M1 single-granulation propellant.) HEAT, HEAT-T, HEP, HEP-T, TP, and TP-T cartridges contain a single, nonadjustable bag charge of M1 single-granulation propellant. The antipersonnel with tracer (APERS-T) cartridge contains a two-zone propelling charge of M30E1 dual-granulation propellant. The HE cartridge RA contains a five-zone white bag charge of dual-granulation propellant in increments 3, 4, 5, 6, and 7.

WARNING

FIRE COMPLETE ROUND ONLY WITH PROJECTILE, CARTRIDGE CASE, AND PROPELLING CHARGE TYPE AS ORIGINALLY PACKED.

(4) Procedure. Rounds with an adjustable (semifixed) propelling charge have the charge divided into increment charges. When the rounds are fired at full charge, the charge is used as issued. When other than full charge is to be fired, adjust the propelling charge as indicated below:

- Remove the projectile from the cartridge case. Be careful not to damage the lip of the case (otherwise, the cartridge may jam in the chamber of the howitzer cannon).
- Withdraw increments from the cartridge case. Remove increments numbered higher than the charge being fired by cutting or breaking the twine between the designated charge and the higher numbered increments.
- Reassemble remaining increments (up to and including the numbered charge to be fired) in the cartridge case in the original order.
- Reassemble fuzed projectile in the cartridge case.

EXAMPLE: When adjusting a seven-section charge for charge 4, remove increments 5, 6, and 7; and then assemble remaining increments 1, 2, 3, and 4 in the cartridge case.

NOTE: Insofar as the propelling charge is concerned, the cartridge is now ready for firing.

g. Fuze setting. Fuzes, fuze wrenches, and fuze setters were discussed in great detail in subcourse FA 3117-5, Field Artillery Ammunition I; however, Table 5 lists the fuze setting tools needed and used with the various fuzes.

Table 5. Fuze setting tools.

FUZE (SEE NOTE 1)										
PD		MT		MTSQ				VT		FUZE WRENCH OR FUZE SETTER
M78 CP SERIES (NOTE 2)	M557 OR M739	M563 SERIES	M565	M501 SERIES	M577 OR M582	M548	M564	M513 SERIES	M728 OR M732	
	X									M18
				X						M14
X										M16
				X				X	X	M27
		X	X			X	X			M34
					X					M35

X — DENOTES COMPATIBILITY OF FUZES AND FUZE SETTERS.

NOTE 1: ALL FUZES ARE INSTALLED AND TIGHTENED TO THE NOSE OF THE PROJECTILE WITH THE M18 FUZE WRENCH, EXCEPT THE M78 CP-SERIES FUZES.

NOTE 2: THE M78 CP-SERIES FUZES AND BOOSTERS ARE INSTALLED IN THE PROJECTILES WITH THE M16 FUZE WRENCH.

TABLE 5

h. Preparation for loading. If required, clean the projectile and cartridge case.

- Ensure that the round is free of sand, mud, moisture, snow, ice, grease, or other foreign matter.
- Inspect the cannon chamber to ensure it is free of obstructions. Remove residual buildup from the protective coating of the cartridge case.

i. Assembly and loading. Assemble the projectile to the cartridge case.

NOTE: During assembly, protect the cartridge case primer.

- Ensure the U-shaped packing stop has been removed from the wrench slots in the fuze of the projectile.
- Load, taking care not to strike the fuze against the weapon.

CAUTION

IN AMMUNITION ASSEMBLED WITH THE M14B2 (M14E1) CARTRIDGE CASE, THE MOUTH OF THE CASE CAN BE EXPANDED SLIGHTLY BY UNCOILING. THIS MAKES IT EASIER TO INSERT THE PROJECTILE IN THE MOUTH OF THE CASE. HOWEVER, IF THE LOADER IS NOT CAREFUL TO GRASP THE PROJECTILE AT ITS POINT OF BALANCE, THE COMPLETE ROUND MAY SAG EXCESSIVELY IN THE CENTER. IF THE LIP OF THE MOUTH OF THE CASE IS ON THE BOTTOM, IT MAY PROTRUDE ENOUGH TO CATCH ON THE LIP OF THE LOWER EXTRACTOR RECESS IN THE CHAMBER. THE MOUTH WILL THEN BEND BACK, MAKING IT IMPOSSIBLE TO CHAMBER THE ROUND. TO PREVENT THIS, THE PROJECTILE MUST BE GRASPED AT ITS BALANCE POINT TO KEEP THE COMPLETE ROUND FROM SAGGING.

j. Rounds prepared for firing but not fired. Using the applicable fuze setter (Table 5), reset the fuzes of rounds prepared for firing but not fired to SAFE or the original setting. Reassemble cartridge components, and repack them in the original packing.

PRACTICE EXERCISE:

8. HE rounds for the 105-mm howitzer do not require preparation of the--
 - A. projectile
 - B. propelling charge
 - C. fuze
 - D. primer

9. Cartridges are packed in--
 - A. individual fiber containers
 - B. metal containers
 - C. aluminum containers
 - D. fiberglass containers

10. BD fuzes do not require setting or other adjustment before firing. These fuzes are used with--
 - A. smoke and WP rounds
 - B. HEAT and HEP rounds
 - C. gas rounds
 - D. HE RA rounds

ANSWERS:

8. D
9. A
10. B

4. MAINTENANCE.

a. Care. Ammunition is packed to withstand conditions ordinarily encountered in the field. Keep packing boxes from becoming broken or damaged. Since ammunition is impaired by moisture, frost, extreme temperatures, and foreign matter (mud, oil, etc.)--

- Do not break the moisture-resistant seal on the container until ammunition is to be used.
- Shield ammunition, particularly fuzes and propelling charges, from sources of high temperatures (e.g., the direct rays of the sun).

b. Handling. Cartridge cases are easily dented and must be protected from hard knocks and blows. A dented cartridge case may result in loss of obturation, jamming in the chamber, and difficulty in extraction.

(1) Protect propellant. Protect the propellant from foreign matter and moisture during handling. Keep the mouth of the cartridge case containing the propellant covered when moving ammunition. Place one fiber cap over the top of the cartridge opening and one fiber cap under the bottom of the cartridge to protect the primer.

(2) Protect fuzes. Protect fuzes, primers, and rotating bands at all times from foreign matter and impact.

c. Maintenance procedures.

(1) Inspect the ammunition packaging daily. Open boxes or containers that show severe evidence of contamination or deterioration, and inspect ammunition. Do not open sealed boxes or containers only for inspection purposes.

(2) Inspect unpackaged ammunition and explosive components daily.

(3) Wipe off wet or dirty ammunition at once. Remove any light corrosion.

CAUTION

DO NOT POLISH AMMUNITION TO MAKE IT LOOK BETTER.

(4) Consider ammunition that exhibits severe rust or propellant contamination, particularly moisture, as unserviceable. Do not use except in emergencies.

(5) Repackage serviceable ammunition in original containers, ensuring all material is dry and sound. If the original container is unsuitable, use the expended material container and transfer all markings.

d. Ammunition prepared for firing but not fired.

(1) Return such ammunition to the original condition and packing. Mark appropriately, and use first in subsequent firings to keep stocks of open packing to a minimum.

(2) Reassemble the supplementary charge and closing plug (with gasket and spacer) or fuze to the projectile to restore the round to its original condition. Return fuzes to original packaging. In reassembling the components, make certain the supplementary charge is properly inserted. The felt pad must be present. The supplementary charge is inserted with the pad end first.

e. Unserviceable ammunition.

(1) Conspicuously mark unserviceable ammunition or explosive components UNSERVICEABLE, and return them to the ammunition supply personnel for disposition.

(2) Repackage the ammunition in original containers. If the original container is unsuitable, use the expended material container and transfer all markings. All layers of packing must be conspicuously marked UNSERVICEABLE.

f. Excess explosive components.

(1) Pack supplementary charges removed from projectiles before assembling long-intrusion VT fuzes in the containers from which the VT fuzes were removed.

(2) Properly mark the container, and return it to the ammunition supply personnel for disposition.

PRACTICE EXERCISE:

- 11. T F A dented cartridge case may result in loss of obturation, jamming in the chamber, and difficulty in extraction.
- 12. T F While inspecting ammunition packaging, sealed boxes or containers should not be opened only for inspection.
- 13. T F If ammunition is found to be unserviceable, the ammunition or explosive components should be conspicuously marked UNSERVICEABLE and returned to the ammunition supply personnel for disposition.

ANSWERS:

- 11. T
- 12. T
- 13. T

5. MISFIRE SAFETY PROCEDURES, The malfunctions described below are rarely encountered when authorized; properly maintained ammunition is fired in properly maintained and operated weapons. However, to avoid injury to personnel and damage to equipment, it is important that those concerned understand the nature of these malfunctions and be familiar with preventive and corrective procedures.

WARNING

IN THE EVENT OF A FAILURE TO FIRE, KEEP THE WEAPON TRAINED ON THE TARGET. HAVE PERSONNEL STAND CLEAR OF THE MUZZLE AND THE PATH OF RECOIL.

WARNING

DO NOT REUSE ROUNDS EXTRACTED FROM THE WEAPONS BY RAMMING EXTRACTION DIFFICULTY MAY HAVE BEEN CAUSED BY SOME NONSTANDARD CONDITION IN THE AMMUNITION. ALSO, THE FUZE MAY HAVE BEEN DAMAGED DURING THE RAMMING PROCESS.

a. Malfunctions. Artillery cannons and ammunition rarely fail to work properly if maintained and handled correctly. However, should a mishap occur, you can avoid injury and damage by quickly recognizing and correcting the malfunctions. The three types of firing malfunctions--misfires, hang fires, and cook offs--are described below.

(1) Misfire. A misfire is a failure of a round to fire (failure to propel the projectile) after initiating action is taken. The failure may be because of a faulty firing mechanism or a faulty element in the propelling charge explosive train. A misfire in itself is not dangerous; however, it cannot be distinguished from a delay in functioning of the weapon firing mechanism or from a hang fire. Therefore, misfires must be treated as delayed firings until otherwise determined. Such delay in the functioning of the firing mechanism, for example, could result in the presence of foreign matter such as grit, sand, frost, ice, or improper or excessive oil or grease, which might create a partial mechanical restraint.

(2) Hang fire. A hang fire is a delay in the functioning of a propelling charge explosive train (primer, igniter, or propellant) at the time of firing. The delay, though unpredictable, ranges from a fraction of a second to several minutes. A hang fire cannot be distinguished immediately from a misfire.

(3) Cook off. A cook off is a functioning of any or all of the explosive components of a round chambered in a hot weapon. If the primer or propelling charge should cook off, the projectile may be fired from the weapon with normal velocity even without trying to fire the primer by actuating the firing mechanism. Of the three malfunctions, a cook off is the most dangerous. Should the projectile explode in the tube, the blast could destroy the howitzer and kill anyone standing nearby.

b. Loading and unloading. Before we discuss the steps to be taken in case of a misfire, hang fire, or cook off, we should consider loading precautions that will help to prevent a malfunction. Besides observing the prescribed precautions for handling and loading ammunition, you can reduce the chances of a malfunction by--

(1) Not using more than the maximum authorized amount of propellant.

(2) Not loading rounds until just before firing.

(3) Firing or extracting a round in a hot tube within 5 minutes of loading. Since there is no specific definition of a hot tube, the officer in charge of firing must decide when the danger of a hot tube exists. He bases his decision on the ambient temperature, the rate of fire, and the charge being fired. In an actual hot tube situation if a misfire is not involved and the round in the hot tube cannot be fired or removed, the officer in charge must take the following actions:

- Immediately remove the cartridge case.
- Elevate the tube to about 550 mils (30ø) to keep any melted filler in the projectile from leaking into the fuze well.
- Evacuate all personnel to a safe distance.
- Allow the weapon to cool for 2 hours.
- Notify direct support (DS) maintenance and the explosive ordnance detachment (EOD).
- At the end of the 2-hour waiting period, move the weapon to a remote area for safety, if necessary. Before moving the weapon, lower and lock the tube in travel position; place waste material in the chamber for cushioning between the base of the projectile and breech block; and close the breech.
- Release the weapon to ordnance if required.

c. Misfire procedures. If the cannon fail to fire at the first try, try to fire it two more times. If the last try fails, your next actions will depend upon whether the tube is cold or hot.

(1) Procedures after failure to fire--cold tube (Figure 5). After the howitzer fails to fire, notify (FDC) of the misfire. Actuate the firing mechanism two more times in an attempt to fire the piece. If the weapon still fails to fire, the chief of section reports to the executive officer MISFIRE NUMBER (so-and-so). The chief of section then waits 2 minutes from the last attempt to fire before he opens the breech, removes the cartridge case, and inspects the primer to see if it has been dented. If the primer is dented, replace the canister with a new one and fire the weapon. If the primer is not dented, the firing mechanism should be repaired. If the executive officer does not wish to fire the round after the 2-minute waiting period, the projectile must then be removed from the tube. Using the bell rammer to avoid damaging the fuze, the cannoneer pushes the round out the rear of the tube. The breechblock should be closed and rags should be stuffed into the powder chamber to cushion the shock of the projectile. A common cause of a misfire with the 105-mm howitzer is that the breechblock is not fully closed. This will cause the firing pin to miss the primer. Broken or bent firing pins will cause misfires, as will wet powder or a faulty primer.

(2) Procedures after failure to fire--hot tube (Figure 6). After the howitzer fails to fire, actuate the firing mechanism two more times in an attempt to fire the weapon. If the weapon still fails to fire, the chief of section reports to the executive officer MISFIRE NUMBER (so-and-so). The chief of section waits 2 minutes from the last attempt to fire before he opens the breech, removes the cartridge case, and inspects to see if the primer is dented. If the primer is not dented, the firing mechanism should be repaired. If the primer is dented, he replaces the canister with a new one and fires the weapon. The above procedures must be done within 5 minutes after loading. If the weapon cannot be fired or unloaded within 5 minutes, follow these procedures:

- Evacuate all personnel to a safe distance.
- Keep the weapon laid on safe data.
- Request help from EOD. Release the weapon to ordnance, if required.

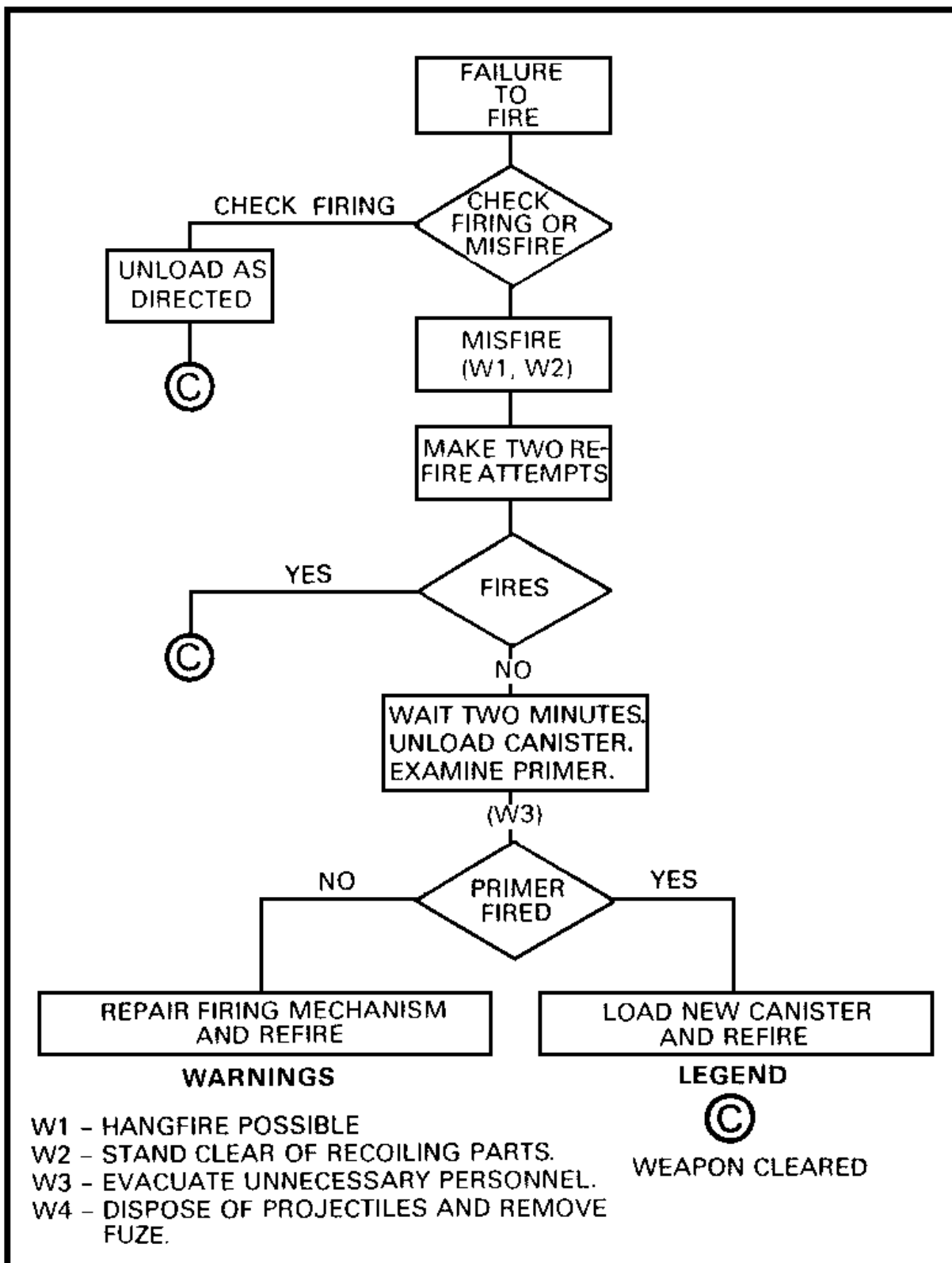

Figure 5. Misfire procedures for weapons firing semifixed ammunition--cold tube.

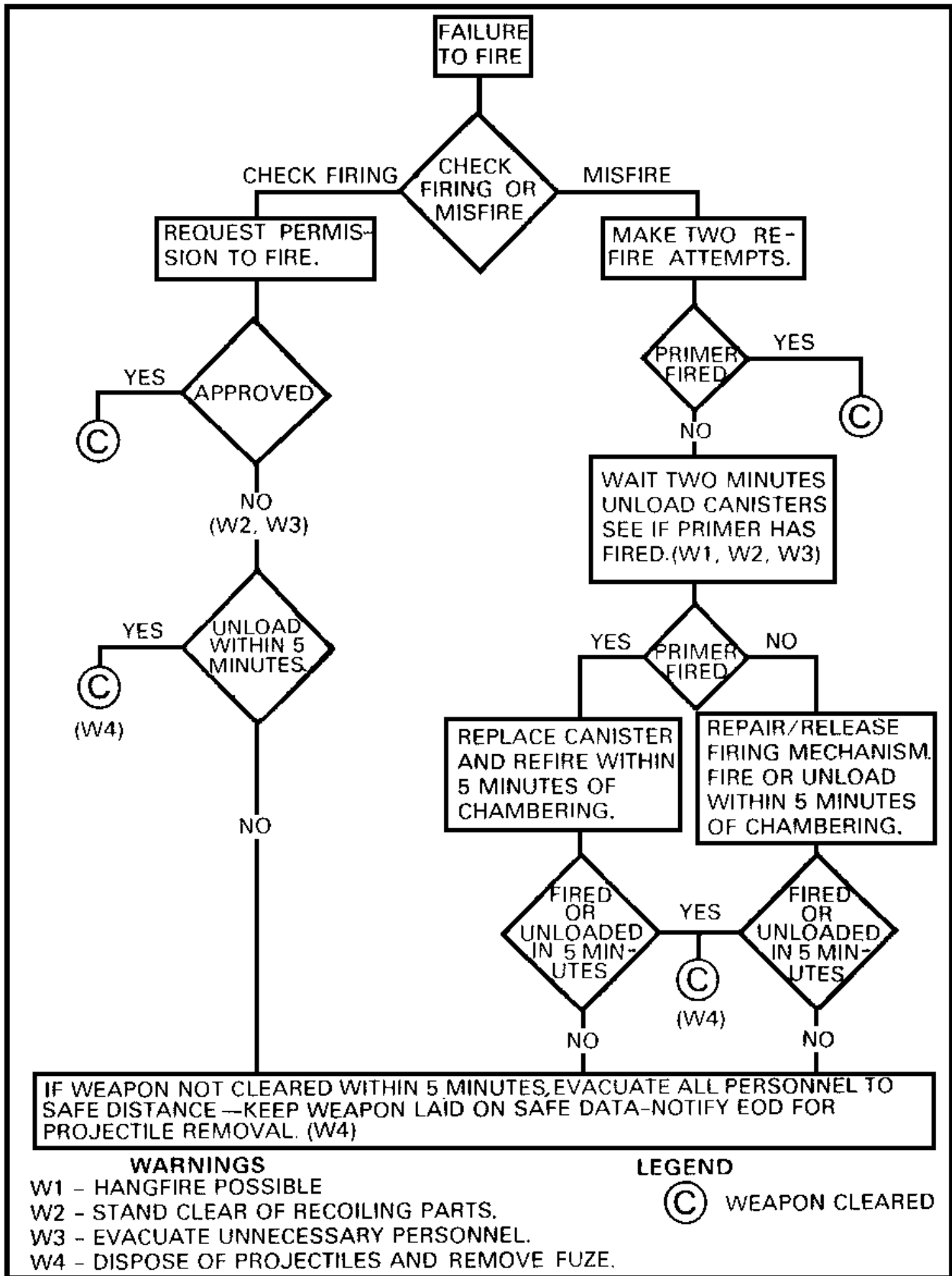

Figure 6. Misfire procedures for weapons firing semifixed ammunition--hot tube.

PRACTICE EXERCISE:

14. In the event of a failure to fire, keep the weapon trained on the _____.
15. The three types of firing malfunctions are misfires, hang fires, and _____.
16. A misfire in itself is not dangerous; however, it cannot be distinguished from a delay in functioning of the weapon firing mechanism or from a _____.
17. Of the three malfunctions, a _____ is the most dangerous.
18. During misfire procedures, if the cannon fail to fire at the first try, try to fire it _____ more times.
19. A common cause of a misfire with the 105-mm howitzer is that the _____ is not fully closed. This will cause the firing pin to miss the _____.

ANSWERS:

14. Target.
15. Cook offs.
16. Hang fire.
17. Cook off
18. Two
19. Breechblock, primer.

6. SUMMARY.

- a. The 105-mm howitzer is a general-purpose, light, towed, field artillery weapon normally used in direct support of an airborne, air assault, or light infantry brigade.
- b. The four major components of the 105-mm howitzers M102 and M119 are the carriage, barrel and breech assemblies, recoil mechanism, and sighting and laying equipment.
- c. Ammunition for the 105-mm howitzer is classified as semifixed. The cartridge case comes free fitted, rather than crimped, over the projectile base. Most cartridges for the 105-mm howitzer require preparation of the projectile, propelling charge, and fuze.
- d. Ammunition is packed to withstand conditions ordinarily encountered in the field. However, keep packing boxes from becoming broken or damaged, and take precautions to keep ammunition from being impaired by moisture, frost, extreme temperatures, and foreign matter.
- e. The three malfunctions that can occur in the firing of cannon ammunition are a misfire, hang fire, and cook off. Learn the exact steps to take when any of these malfunctions occur.

Lesson 2
155-MM WEAPONS USING SEPARATE-LOADING AMMUNITION

OBJECTIVE

Upon completion of this lesson, you will be able to identify and record the characteristics and functioning capabilities of the 155-mm howitzers, both towed and self-propelled, and the ammunition components used. In addition, you will be able to recall and list the different types of malfunctions and prescribed misfire procedures.

REFERENCES

This subcourse is based on TM 43-0001-28 and other materials approved for US Army field artillery instruction; however, development and progress render the text continually subject to change. Therefore, base your examination answers on materials presented in this subcourse rather than on individual or unit experience.

INTRODUCTION

8. 155MM M198 TOWED HOWITZER.

a. M198 description. The M198 155-mm towed howitzer is a medium artillery weapon (Figures 9, 10, and 11) designed to provide DS field artillery fire in the infantry divisions. The M198 is an extended-range, split-trail weapon that can be towed by vehicle or airlifted by a CH-47D helicopter. The carriage has a retractable suspension system and a top carriage, which can be rotated 3,200 mils to decrease overall length for shipment or storage. The lightweight M198 howitzer has a low profile, may be emplaced rapidly, and has a 6,400-mil speed shift assembly. The firing, stowed, and towed positions for the M198 howitzer is as shown in Figures 9, 10, and 11.

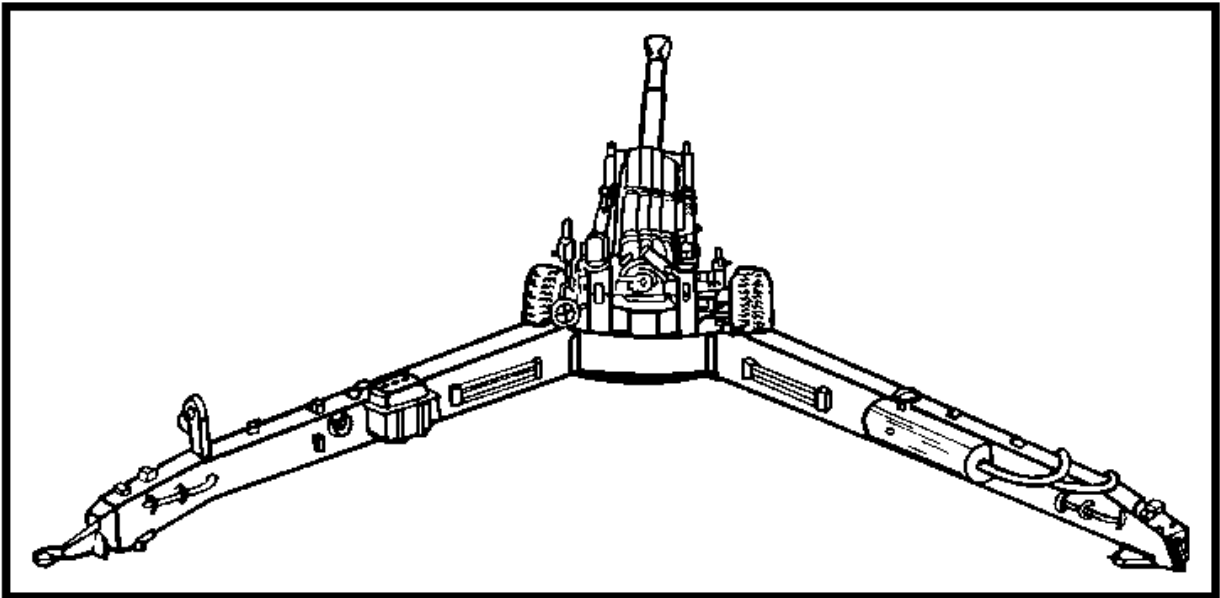

Figure 9. M198 howitzer in the firing position.

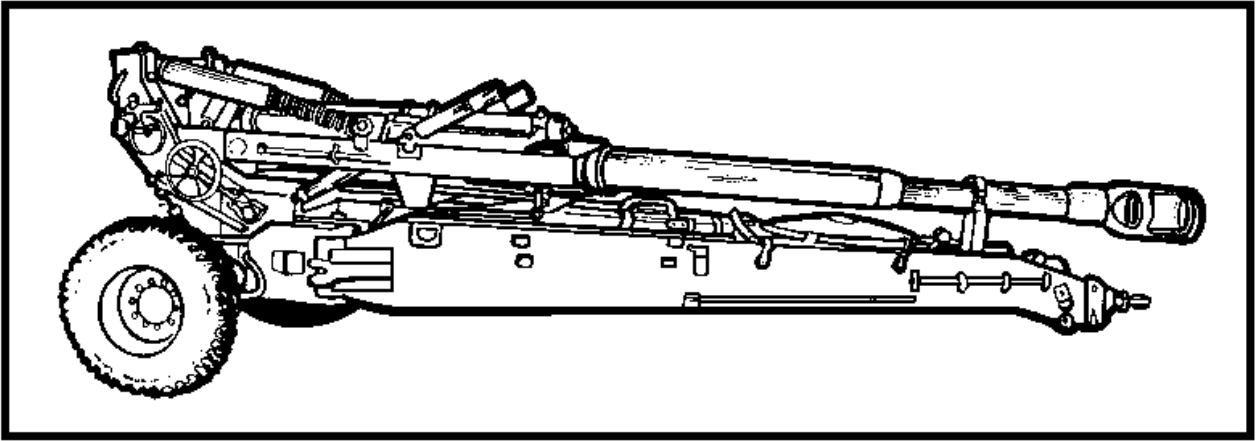

Figure 10. M198 howitzer in the stowed position.

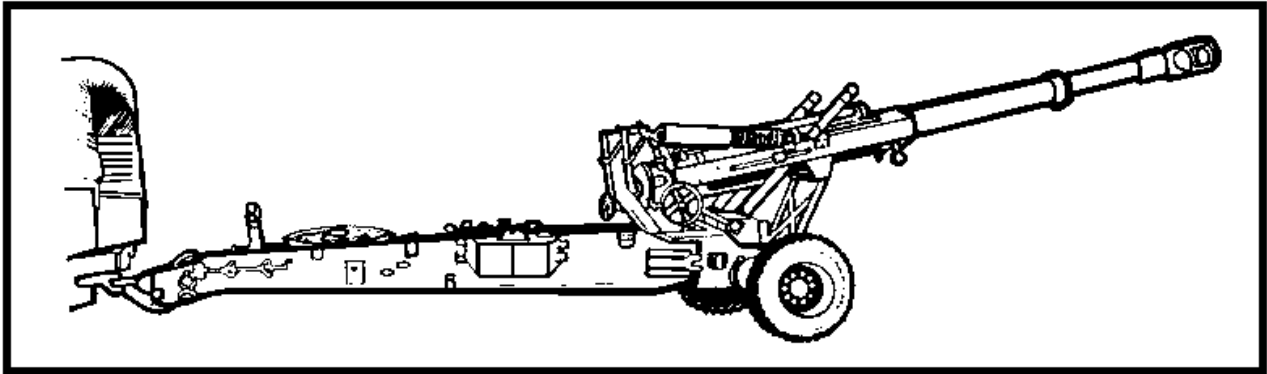

Figure 11. M198 howitzer in the towed position.

b. Tabulated data. The following data pertain to the 155-mm M198 towed howitzer.

Muzzle velocity	826 meters per second
Maximum ranges	24,000 meters (other than RAP) 30,000 meters (RAP)
Type of breechblock	Threaded, interrupted screw
Type of firing mechanism	Continuous pull, M35
Maximum rate of fire	4 rounds per minute for 3 minutes
Sustained rate of fire	2 rounds per minute for 30 minutes, 1 round per minute thereafter

PRACTICE EXERCISE:

23. **T F** The M198 howitzer is an extended-range, split-trail weapon that can be towed by vehicle or airlifted by helicopter.
24. **T F** The lightweight M198 howitzer has a 3,200-mil speed-shift assembly.

ANSWERS:

23. T
24. F

9. 155-MM M109A5/A6 SELF-PROPELLED HOWITZERS.

a. Description. The 155-mm M109A5/A6 (Figure 12), which is an armored, self-propelled, medium howitzer, is a highly mobile combat support weapon. It has a cruising range of 220 miles at speeds up to 35 miles per hour. Combat loaded, the weapon weighs 55,000 pounds. The M109A5/A6 is equipped with the longer M185 cannon and achieves a range of 18,100 meters (with the RAP round, 23,500 meters). The weapon is equipped with a 24-volt electrical system, with four 12-volt batteries connected in series-parallel. A hydraulic system provides power for traversing and elevating the cannon, for ramming the projectile, and for the equilibrator system.

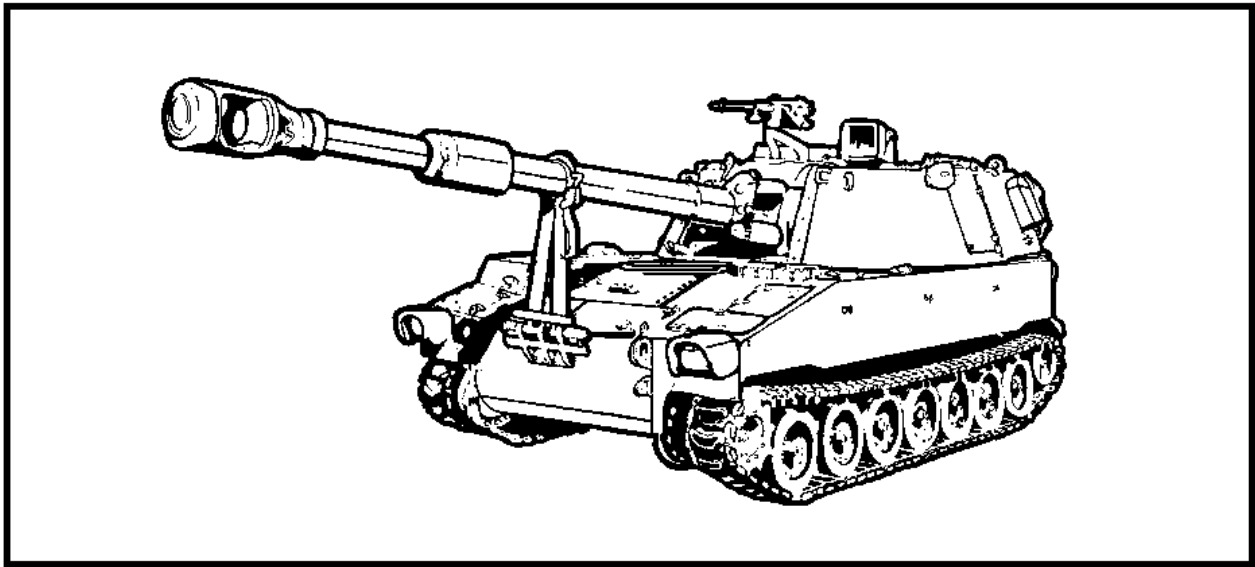

Figure 12. 155-mm self-propelled M109A2/A3 howitzer.

b. Tabulated data. The following data pertain to the 155-mm M109A2/A3 self-propelled howitzer.

Muzzle velocity	701 meters per second
Maximum ranges	14,600 meters (charge 7) 18,100 meters (charge 8) 23,500 meters (RAP)
Type breechblock	Threaded, interrupted screw
Type of firing mechanism	Continuous pull, M35
Maximum rate of fire	4 rounds per minute for 3 minutes
Sustained rate of fire	Charges 1-7, 1 round per minute Charge 8, 1 round per minute for 60 minutes, then 1 round per 3 minutes thereafter

10. AMMUNITION/COMPONENTS FOR THE 155-MM HOWITZER. Ammunition for the 155-mm howitzer cannons (M114/M114A1/A2, M198, and M109A2/A3) is the separate-loading type. The loading of each complete round into the howitzer cannon requires three separate operations:

- Loading the fuzed projectile.
- Loading the propelling charge.
- Inserting the primer.

All four of these components (fuze, projectile, propelling charge, and primer) are shipped separately. The preparation and loading of a complete round is performed by the cannoners and supervised by the chief of section.

a. Identification. Projectile colorings and markings (new and old) are listed in Table 6. Additionally, important information is stenciled on each projectile (Figure 13). Knowledge of the color coding and meaning of the markings will aid in the rapid selection of the required projectile when firing. Know your ammunition.

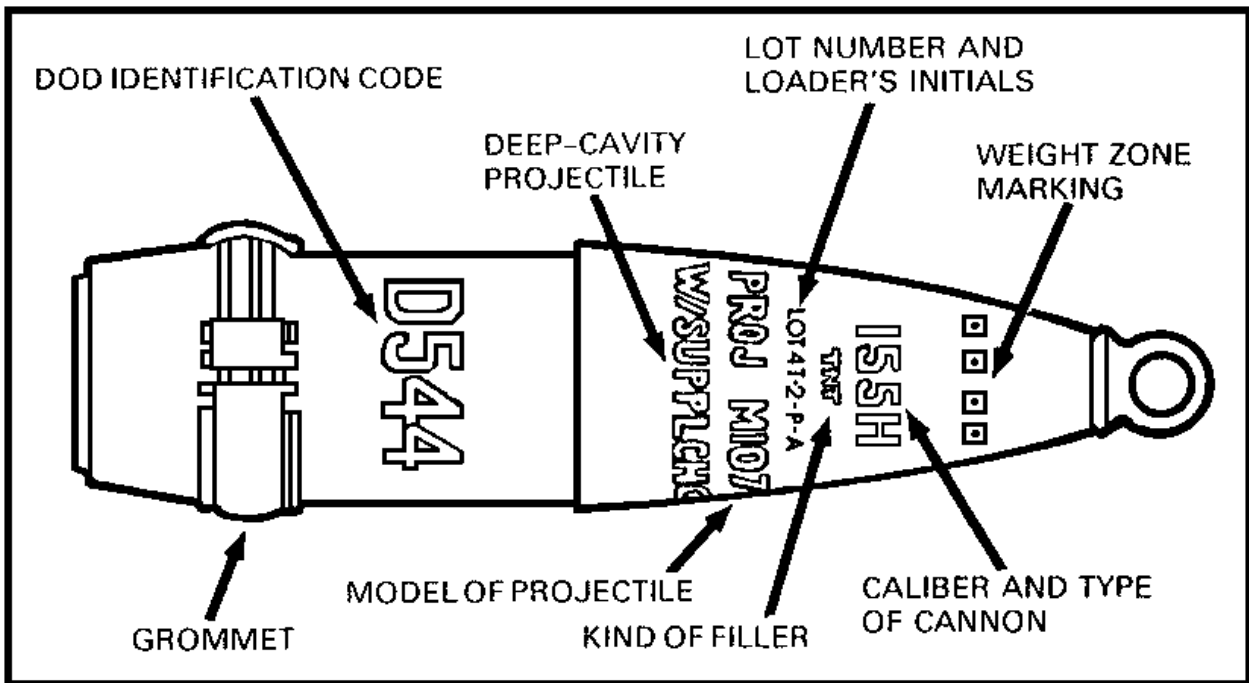

Figure 13. Marking of the 155-mm HE projectile.

Table 6. Model numbers and color coding of projectiles
for the 155-mm howitzer.

TYPE AND MODEL NUMBER OF PROJECTILE	NEW MANUFACTURE			OLD MANUFACTURE		
	COLOR OF PROJECTILE	NUMBER/COLOR OF BANDS	MARKING	COLOR OF PROJECTILE	NUMBER/COLOR OF BANDS	MARKING
M110, AGENT (H, HD) WITH BURSTER	GRAY	2/GREEN 1/YELLOW	GREEN	GRAY	2/GREEN	GREEN
M121A1, AGENT (GB OR VX), WITH BURSTER	GRAY	3/GREEN 1/YELLOW	GREEN	GRAY	GB1/ GREEN VX2/ GREEN	GREEN
M449 SERIES, HE, ICM	OLIVE DRAB	DIAMONDS*	YELLOW	OLIVE DRAB	NONE	YELLOW
M483A1, HE, DP, ICM	OLIVE DRAB	DIAMONDS*		NA		
M107, HE, COMPOSITION B AND TNT FILLER, WITH AND WITHOUT SUPPLEMENTARY CHARGE	OLIVE DRAB	NONE	YELLOW	OLIVE DRAB	NONE	YELLOW
M485A1, M485A2, ILLUMINATING	OLIVE DRAB	1/WHITE	WHITE	NA		
M116, M116B1, SMOKE, BE. (HC)	NA			GRAY	1/YELLOW	YELLOW
M116A1	LIGHT GREEN	NONE	BLACK		NA	
M110 (M110E1), M110A1 (M110E2), M110A2 (M110E3), SMOKE (WP)	LIGHT GREEN	1/YELLOW	RED	GRAY	1/YELLOW	YELLOW
M549, M549A1, HERA	OLIVE DRAB	NONE	YELLOW	NA		
M692, HE (ADAM-L**)	OLIVE DRAB	TRI- ANGLES***	(L) YELLOW	NA		
M731, HE (ADAM-S**)	OLIVE DRAB	TRI- ANGLES***	(S) YELLOW	NA		

Table 6. Model numbers and color coding of projectiles
for the 155-mm howitzer (continued).

TYPE AND MODEL NUMBER OF PROJECTILE	NEW MANUFACTURE			OLD MANUFACTURE		
	COLOR OF PROJECTILE	NUMBER/COLOR OF BANDS	MARKING	COLOR OF PROJECTILE	NUMBER/COLOR OF BANDS	MARKING
M718, HE (RAAMS-L****)	OLIVE DRAB	8 TRI-ANGLES***	(L) YELLOW	NA		
M741, HE (RAAMS-S****)	OLIVE DRAB	8 TRI-ANGLES***	(S) YELLOW	NA		
M712, HEAT (COPPERHEAD)	BLACK	NONE	YELLOW	NA		
M823, TRAINING	BRONZE	NONE	BLACK	NA		
M804, PRACTICE	BLUE	1/BROWN	WHITE	NA		

*ROW OF YELLOW DIAMONDS BETWEEN NOSE AND BOURRELET OF PROJECTILE.

**AREA DENIAL ARTILLERY MUNITION (ADAM). SUFFIX S OR L REFERS TO SELF-DESTRUCT TIME. SUFFIX S = SHORT TIME (LESS THAN 24 HOURS), AND SUFFIX L = LONG TIME (MORE THAN 24 HOURS).

***YELLOW TRIANGLES BETWEEN THE NOSE AND BOURRELET OF PROJECTILE WITH LETTER S AND L PAINTED INSIDE THE TRIANGLE.

****REMOTE ANTIARMOR MINE SYSTEM (RAAMS). SUFFIX S OR L INDICATES SHORT OR LONG SELF-DESTRUCT TIME.

b. Authorized rounds. Authorized projectiles, propelling charges, and fuzes are listed in Table 7 for the M198 and M109A5/A6 howitzers.

NOTE: Projectiles of current manufacture that contain deep fuze cavities (except for the M549/M549A1 HE RA projectiles) and supplementary charges of TNT are suitable for use with the long-intrusion (M728) or the new short-intrusion (M732) VT fuzes. The only difference is that the supplementary charge must be removed when the older; long-intrusion VT fuze is used. It must remain in place whenever any other authorized fuze, to include the new short-intrusion VT fuze, is used. Deep-cavity projectiles are identified by the words W/SUPPL CHG marked on the projectile. Weight zones are indicated on projectiles by means of one or more squares of the same color as the marking. Four squares indicate standard or normal weight of the 155-mm projectiles, which need no weight corrections when firing data are computed.

c. Projectile characteristics. Projectiles were discussed in great detail in subcourse FA 3117; however, listed below is a brief description of some of the authorized projectiles and their characteristics for the 155-mm howitzers.

(1) Projectile, 155-mm, HE, M107. Used mainly for blast, fragmentation, and mining, this deep- or shallow-cavity projectile consists of a steel case loaded with either TNT or composition B. Point detonating time, or VT fuzes may be used.

(2) Projectile, 155-mm, gas, persistent, H or HD, M110. The filler of this projectile produces a toxic effect on personnel and is also used to contaminate habitable areas. This projectile is filled with either H or HD (mustard) gas with a built-in booster charge.

(3) Projectile, 155-mm, gas, persistent, VX, M121A1. This projectile contains VX (nerve) gas, which produces a toxic effect on personnel. A booster charge bursts the projectile.

(4) Projectile, 155-mm, smoke, WP, M110E1, and M110 WP. The fillers of smoke projectiles M110 and M110E1 have a slight burning effect but are used mainly to produce screening smoke. The projectile is similar to the M110 gas projectile and has the same characteristics as the M107 HE.

(5) Projectile, 155-mm, illuminating, M485. This projectile is used for battlefield illumination. The base-ejection type projectile consists of a hollow steel body containing an ejection charge and canister and parachute assembly.

Table 7. Authorized projectiles, propelling charges, and fuzes for howitzers M114/M114A1/A2, M198, and M109A2/A3.

M198						
PROJECTILES	PROP CHARGES				MAXIMUM RANGE	FUZE ACTIONS
	M3 SERIES	M4 SERIES	M119 SERIES	M203		
M107 HE	YES	YES	YES	NO	18,150	CP, PD, MTSQ, VT
M549A1 RAP	NO	YES, but Zone 7 only	*YES, But Not M119	YES	30,000	PD
M449 ICM	YES	YES	YES	NO	18,100	MT
M485 ILLUM	YES	YES	YES, But Degraded Reliability	NO	17,500	MT
M483A1 OP-ICM	YES, But not Zones 1 or 2	YES	YES	NO	17,500	MT
M682/M731 ADAM	YES, But not Zones 1 or 2	YES	YES	NO	17,500	MT
M454 NUC	PROB COMPATIBLE USES SPECIAL PROP CHARGES				CLASSIFIED	AIRBURST
M116A1HC	YES	YES	YES	NO	18,150	MT
M110 WP	YES	YES	YES	NO	18,150	PD, MTSQ
M687 BINARY	Not Zones 1 or 2	YES	YES	PROB COMP	TBD	PD, MTSQ
M121 CHEMICAL	YES	YES	YES	NO	18,150	PD, VT
M795 HE	Not Zones 1 or 2	YES	YES	YES	22,400	PD, MTSQ, VT (M732 VT only)
XM785 NUC	Not Zones 1 or 2	PROBABLY COMPATIBLE			30,100	AIRBURST
XM825 SMOKE	Not Zones 1 or 2	PROBABLY COMPATIBLE			TBD	MT
M718/M741 RAAM	YES, But not Zones 1 or 2	YES	YES	NO	17,500	MT
M712 COPPERHEAD	YES, But no requirement for zones 1 thru 3	YES	YES	NO	16,400	BD (Comes already installed)
XM694/XM694E1	PROBABLY COMPATIBLE				TBD	MT
M804 PRACTICE	YES	YES, Zone 5 Max	PROB COMP	NO	9,700	PD

*M119-series consist of M119 or M119A1 white bag, zone 8s, and M119A2 red bag, zone 7. CAUTION: M119 propelling charge not authorized with any M549/M549A1 or any other rocket-assisted projectiles (RAP).

**M109A1 can shoot zones 4, 5, or 6. Can shoot zone 7 in combat emergency only.

***M109A2 or M109A3 can shoot M712 projectile with M119A1 or M119A2 propelling charges to a range of 16,400 meters.

KEY TO ABBREVIATIONS			
ADAM	Area denial artillery munitions	IOC	Initial operations capability
apers	Antipersonnel	MAMT	Muzzle action, mechanical time
BD	Base detonating	MOD	Modified
BE	Base ejection	MT	Mechanical time
CP	Concrete piercing	MTSQ	Mechanical time superquick
CS	A tactical riot control agent	PD	Point detonating
DPICM	Dual-purpose improved conventional munition	PIBD	Point initiating, base detonating
		PROX	Proximity
FASCAM	Family of scatterable mines	RAAMS	Remote antiarmor mine systems
GB	Nonpersistent toxic (casualty)	RAP	Rocket-assisted projectile
H	Mustard gas	REMBASS	Remote battlefield aerial surveillance system
HC	Hexachloroethane (rocket)		
HD	Distilled mustard gas	RDF	Rapid Deployment Forces
HE	High-explosive	TBD	To be determined
HEAT	High-explosive antitank	VT	Proximity fuze
HEP	High-explosive plastic	VX	Persistent toxic (casualty) nerve gas
ICM	Improved conventional munitions	WP	White phosphorus
ILLUM	Illuminating		

M109A1 /A2/A3 SP HOWITZER

PROJECTILES	PROP CHARGES				MAXIMUM RANGE	FUZE ACTIONS
	M3 SERIES	M4 SERIES	M119 SERIES	M203		
M107 HE	YES	YES	YES	NO	18,100	CP, PD, MTSQ, VT
M549A1 RAP	NO	YES, But Zones 7 only	* YES, But Not M119	NO	23,500	PD
M449 ICM	YES	YES	YES	NO	14,100	MT
M485 ILLUM	YES	YES	YES, but Dependent Reliability	NO	17,500	MT
M483A1 DP-ICM	YES, But Not Zones 1 or 2	YES	YES	NO	17,500	MT
M692/M731 ADAM	Yes, But Not Zones 1 or 2	YES	YES	NO	17,500	MT
M454 NUC	USES SPECIAL PROP CHARGES			NO	CLASSIFIED	AIRBURST
M118A1 HC	YES	YES	YES	NO	18,100	MT
M110 WP	YES	YES	YES	NO	18,100	PD, MTSQ
M687 BINARY	YES, But Not Zones 1 or 2	YES	YES	NO	TBD	PD, MTSQ
M121 CHEMICAL	YES	YES	YES	NO	18,100	PD, VT
M795 HE	YES, But Not Zone 1 or 2	YES	PROB COMP	NO	TBD	CP, PD, MTSQ, VT, (M732 only)
XM785 NUC	PROBABLY COMPATIBLE, BUT NOT ZONES 1 or 2			NO	23,500	AIRBURST
XM825 SMOKE	PROBABLY COMPATIBLE, BUT NOT ZONES 1 or 2			NO	TBD	MT
M718/M741 RAAM	YES, But Not Zones 1 or 2	YES	YES	NO	17,500	MT
M712 COPPERHEAD	YES, but not requirement for zones 1 thru 3	YES**	YES***	NO	16,400	BD (Comes Already Installed)
XM694/XM694E1 REMBASS	PROBABLY COMPATIBLE			NO	TBD	MT
M804 PRACTICE	YES	YES, Zone 8 Max	PROB COMP	NO	9,700	PD

KEY TO FUZES	
CP	M78, M78A1
PD	M567, M572, M739
MAMT	M563
MT	M565, M577*
MTSQ	M564, M582*
VT	M513, M728, M732

*M577 and M582 can be set for either MT or SQ action, but not for both.

*M119-series consists of M119 or M119A1 white bag, zone 8, and M119A2 red bag, zone 7. CAUTION: M119 propelling charge not authorized with any M549/M549A1 or any other rocket-assisted projectile (RAP).
 **M109A1 can shoot zones 4, 5, or 8. Can shoot Zone 7 in combat emergency only.
 ***M109A2 or M109A3 can shoot M712 projectile with M119A1 or M119A2 propelling charge to a range of 18,400 meters.

M114/M114A1

PROJECTILE	PROP CHARGES		MAXIMUM RANGE	FUZE ACTIONS
	M3 SERIES	M4 SERIES		
M107 HE	YES	YES	14,600	CP, PD, MTSQ, VT
M549A1 RAP	NOT COMP		NOT COMP	
M449 ICM	YES	YES	14,600	MT
M485 ILLUM	YES	YES	13,600	MT
M483A1 DP-ICM	NOT COMP		NOT COMP	
M692/M731 ADAM	NOT COMP		NOT COMP	
M454 NUC	USES SPECIAL PROP CHARGES		CLASSIFIED	AIRBURST
M118A1 HC	YES	YES	14,600	MT
M110 WP	YES	YES	14,600	PD, MTSQ
M687 BINARY	NOT COMP		NOT COMP	
M121 CHEMICAL	YES	YES	14,600	PD, VT
XM795 HE	NOT COMP		NOT COMP	
XM785 NUC	NOT COMP		NOT COMP	
XM825 SMOKE	NOT COMP		NOT COMP	
M718/M741 RAAM	NOT COMP		NOT COMP	
M712 COPPERHEAD	NO REQ FOR Z1 THRU Z3		TBD	BD (Comes already installed)
XM694/XM694E1 REMBASS	NOT COMP		NOT COMP	
M804 PRACTICE	YES	Yes, Zone 8 Max	9,700	PD

M114A2

PROJECTILES	PROP CHARGES		MAXIMUM RANGE	FUZE ACTIONS
	M3 SERIES	M4 SERIES		
M107 HE	YES	YES	14,600	CP, PD, MTSQ, VT
M549A1 RAP	NO	YES, but Zone 7 only	19,300	PD, VT
M449 ICM	YES	YES	14,600	MT
M485 ILLUM	YES	YES	13,600	MT
M483A1 DP-ICM	YES	YES	14,500	MT
M692/M731 ADAM	YES	YES	14,300	MT
M454 NUC	USE SPECIAL PROP CHARGES		CLASSIFIED	AIRBURST
M118A1 HC	YES	YES	14,600	MT
M110 WP	YES	YES	14,600	PD, MTSQ
M687 BINARY	YES	YES	TBD	PD, MTSQ
M121 CHEMICAL	YES	YES	14,600	PD, VT
XM795 HE	PROB COMP		TBD	CP, PD, MTSQ, VT (Only M732)
XM785 NUC	PROB COMP		19,300	AIRBURST
XM825 SMOKE	PROB COMP		TBD	MT
M718/M741 RAAM	YES	YES	14,300	MT
M712 COPPERHEAD	NO REQ FOR Z1 THRU Z3		TBD	BD (Comes already installed)
XM694/XM694E1	PROB COMP		TBD	MT
M804 PRACTICE	YES	YES, Zone 8 Max	9,700	PD

155-mm Propelling Charges

M3 series, green bag with zones 1 through 5.
 M4 series, white bag with zones 3 through 7.
 M119/M119A1, white bag with zone 8 only.
 M119A2, red bag with zone 7 only.
 M203, red bag with zone 8 super, used in M198 towed howitzer only.

(6) Projectile, 155-mm, improved conventional munitions (ICM), M449 series. These projectiles are used mainly against personnel. They are base-ejecting projectiles that contain 60 M43-series grenade submissiles. The grenades are dispersed in the air when the time fuze (M565 MT or M577 MTSQ) functions. When the grenades impact, submunitions are ejected and explode 4 to 6 feet above the surface, producing fragmentation in a circular pattern (Figure 14).

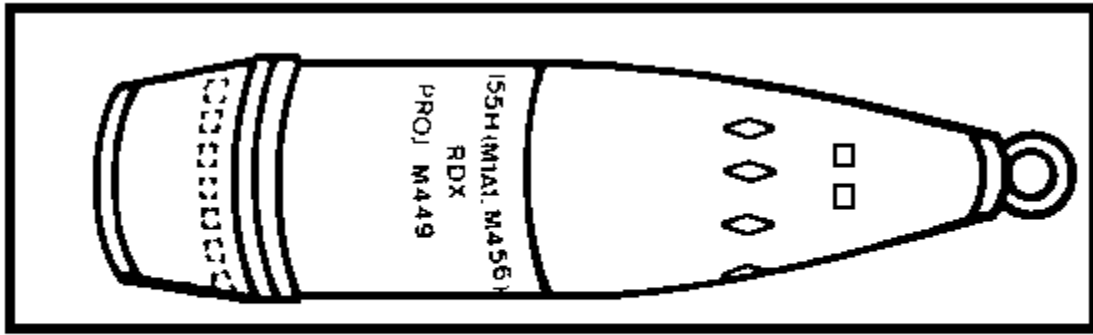

Figure 14. M449-series projectile.

(7) Projectile, 155-mm, ICM, M483A1. This projectile is the latest ICM of the dual-purpose variety--antipersonnel and antimateriel. These high fragmentation, base-ejection type projectiles consist of a steel body containing an expelling charge and 88 shaped charge grenade submissiles. In the fire-for-effect mode, the expelling charge ejects the 88 submissiles from the projectile during flight. The grenades orient themselves in the air stream and activate upon ground or target impact. A shaped charged jet is expelled downward while the body bursts into a large number of high-velocity fragments. The jet can penetrate 2.75 inches of armor plate. In the registration mode, the expelling charge is removed and a projectile spotting charge is attached to the time fuze and installed in the projectile. This will cause the M483A1 projectile to detonate all of the 88 grenades inside the projectile, causing high fragmentation in the same manner as a standard HE projectile. This projectile weighs 102 pounds and uses only the M577 fuze (Figure 15).

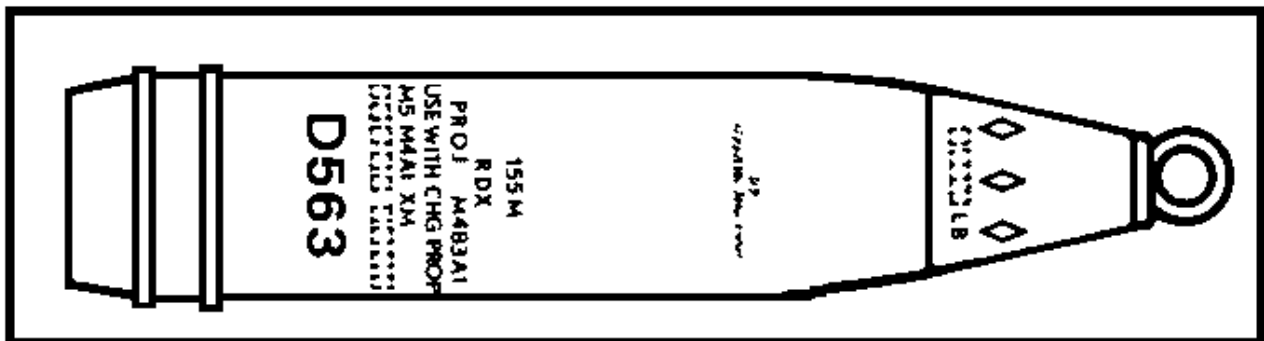

Figure 15. M483A1 projectile.

(8) Projectile, 155-mm, HE, M692. This projectile is known as the area denial artillery munition (ADAM). The most significant markings are the row of yellow triangles with the letter L in them and the letters ADAM-L between the nose and bourrelet. The letter L indicates a long self-destruct time for the submunitions. These submunitions are antipersonnel mines to deny the enemy free use of certain areas for a period of time. This is a base-ejection type projectile and uses the M577 time fuze (Figure 16).

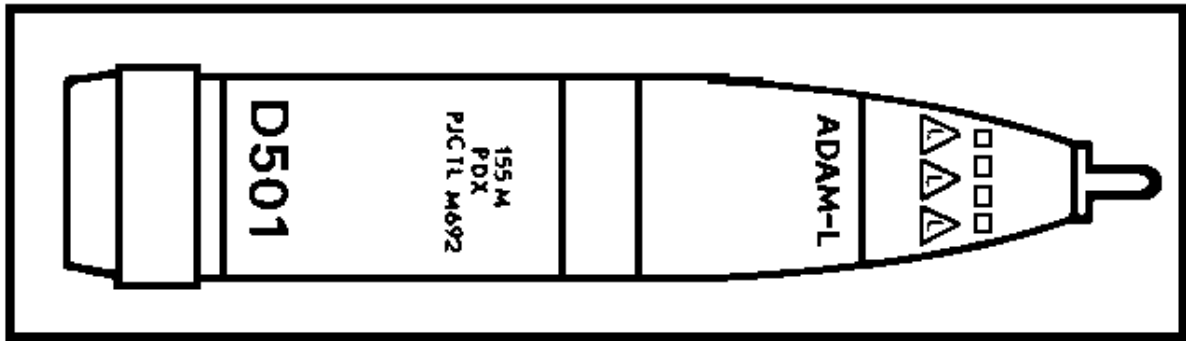

Figure 16. M692 projectile.

(9) Projectile, 155-mm, HE, M731. This projectile is also known as the ADAM round and is exactly like the M692 above except for the letter S painted in each yellow triangles and the letters ADAM-S, which indicate the shorter self-destruct time of the antipersonnel mine submunitions unit. This is a base-ejection type projectile and uses the M577 time fuze (Figure 17).

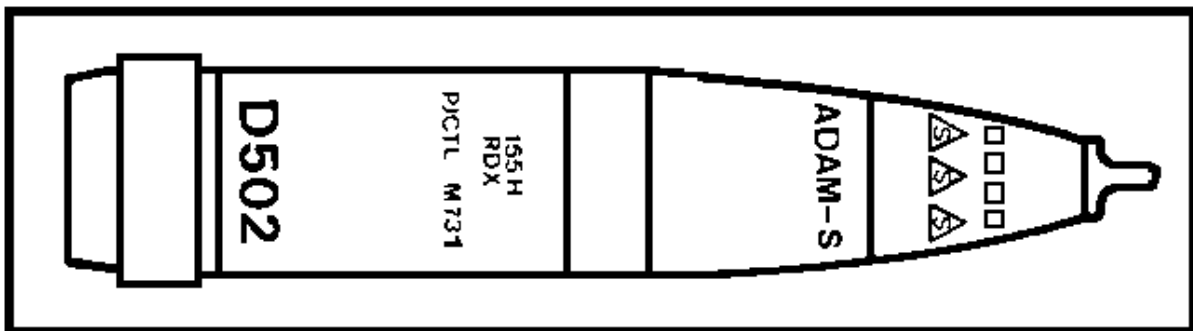

Figure 17. M731 projectile.

(10) Projectile, 155-mm, HE, RAAMS M718. This projectile is used to deliver high-explosive antitank mines in front of enemy armored forces to deny or delay access to a particular area for a specific time period. This projectile is from the family of scatterable mines and is known as the remote antiarmor mine system. It is painted olive drab with yellow markings. The most significant markings are the row of yellow triangles, which contain the letter L, between the nose and the bourrelet and RAAM-L on the ogive, which indicates the long self-destruct time for the submunition (Figure 18). This is a base-ejection type projectile and uses the M577 MTSQ fuze.

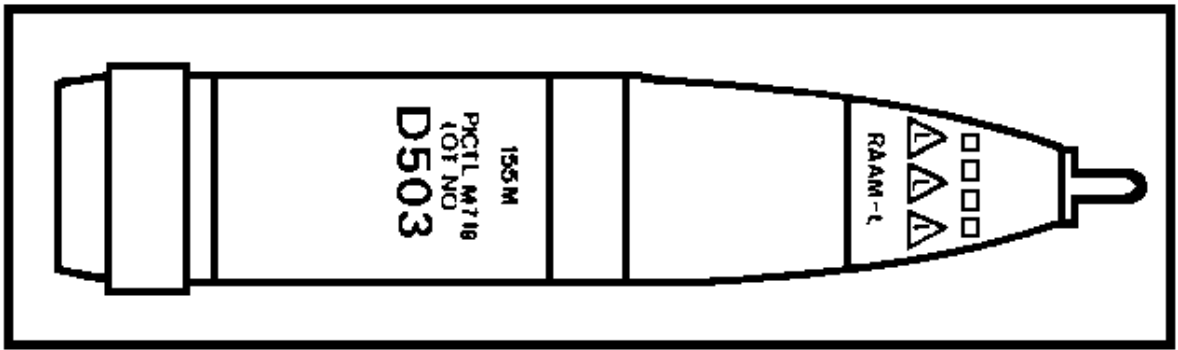

Figure 18. M718 projectile.

(11) Projectile, 155-mm, HE, RAAMS, M741. This projectile is also known as a RAAMS round. It is exactly like the M718 above except the letter S painted in the yellow triangles and the RAAMS-S on the ogive are different to indicate a short self-destruct time. This is a base-ejection type projectile and uses the M577 MTSQ fuze (Figure 19).

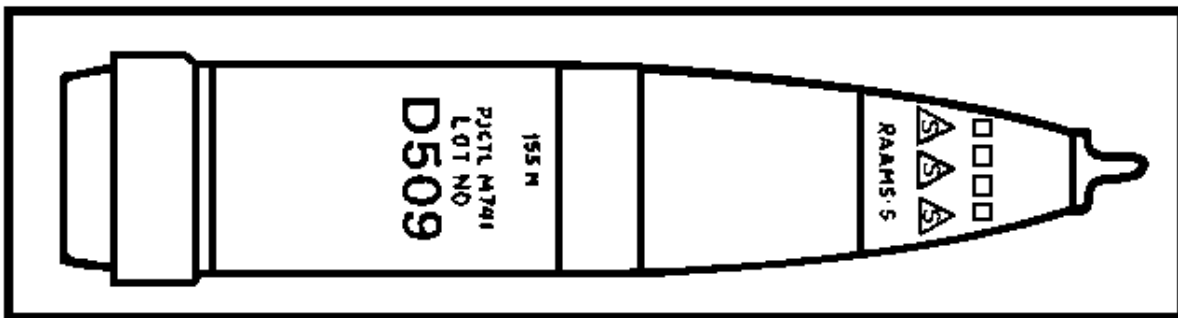

Figure 19. M741 projectile.

(12) Projectile, 155-mm, HEAT, M712. This projectile is a cannon-launched guided projectile (CLGP). It is a HEAT projectile loaded with 14.75 pounds (6.69 kilograms [kg]) of composition B. It is guided to its target by a laser beam directed on the target from a laser designator. The projectile has five time and code switches set by the crew before firing. The warhead section of the projectile contains its own base-detonating fuze (M740). The projectile is 54 inches (137.16 centimeters [cm]) long and weighs 138 pounds (62.60 kg) (Figure 20).

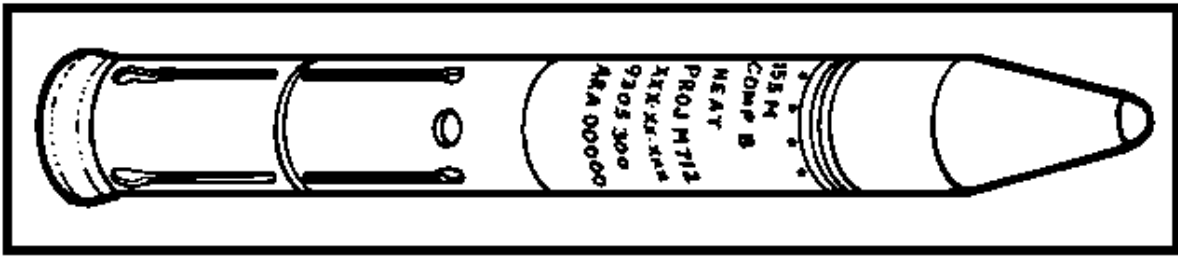

Figure 20. M712 projectile.

(13) Projectile, 155-mm, training, M823. This projectile is designed to train 155-mm howitzer weapon crews in the handling and setting of the M712 projectile. It simulates the M712 in weight, center of gravity, and external appearance (Figure 21). It contains code and time switches that are set to simulate pre fire activity by the crew. It is shipped and stored in the same container as the M712, and is color-coded bronze for easy identification.

WARNING

THE M823 PROJECTILE MUST NOT BE FIRED. SUCH FIRING COULD BE A HAZARD TO PERSONNEL FORWARD OF THE WEAPON.

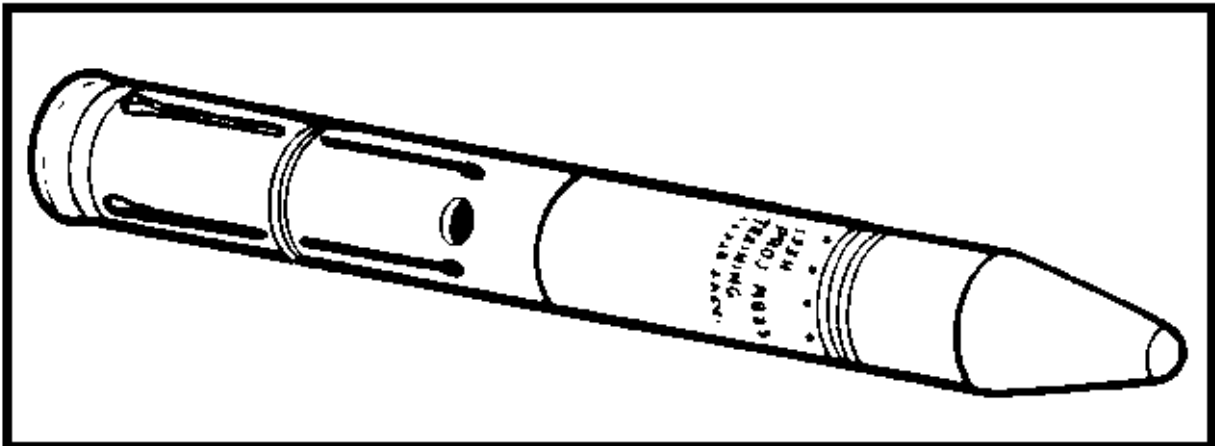

Figure 21. M823 projectile.

d. Propelling charges. The following are authorized propelling charges for the 155-mm howitzers. Refer to Table 2, and compare which weapon system can use the different series of propelling charges. For example, the M114A1 cannot fire the M119-series propelling charges; the M198, when firing the M107 HE, cannot use the M203 propelling charge.

(1) Propelling charge M3A1. This is a green bag charge divided into a base and four increments for firing in zones 1 through 5. It has a flash reducer pad assembled forward of the base charge with similar 1-ounce pads assembled forward of increments 4 and 5. The increment bags are tied together by cloth tying straps. An igniter charge in a red cloth bag is sewn to the rear of the base section

(Figure 22). The igniter pad consists of a red pancake shaped bag of either black powder or clean-burning igniter (CBI).

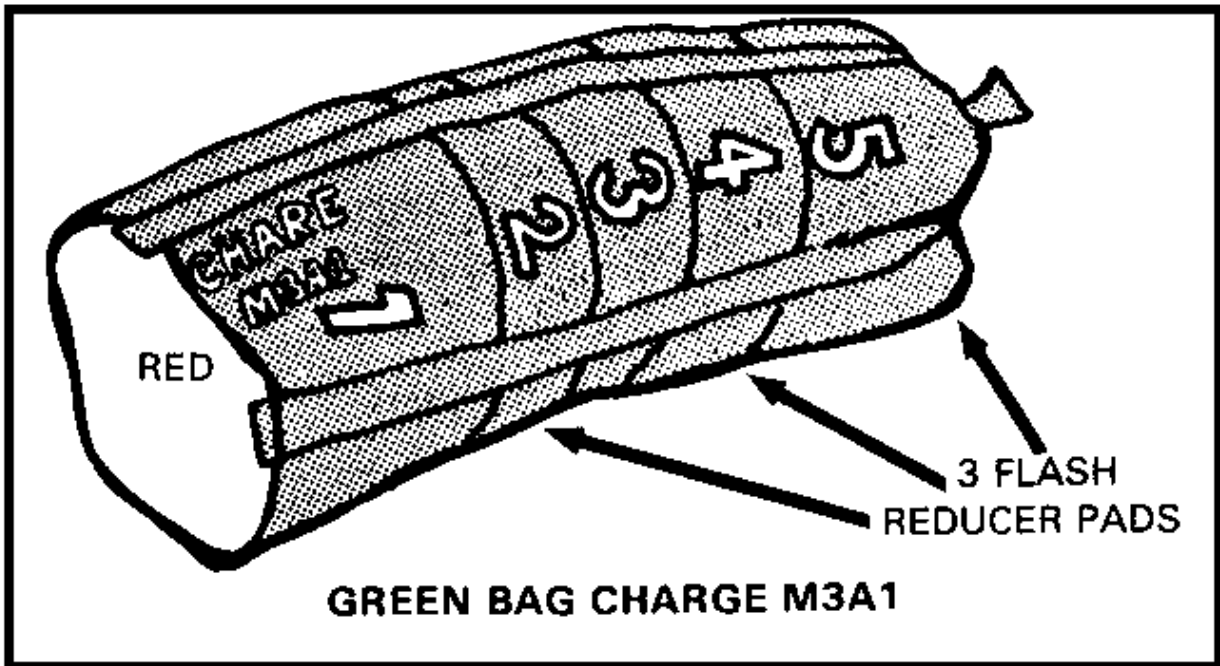

Figure 22. M3A1 propelling charge.

(2) Propelling charge M3. This is a green bag charge similar to propelling charge M3A1, except it is not assembled with a flash reducer and black powder is used in the igniter pad.

(3) Propelling charge M4A2. This is a white bag charge (Figure 23) consisting of a base charge and four increments for firing in zones 3 through 7. The increments are tied together by cloth tying straps. An igniter charge in a red cloth bag is sewn to the rear of the base section. It has a flash reducer pad assembled forward of the base charge.

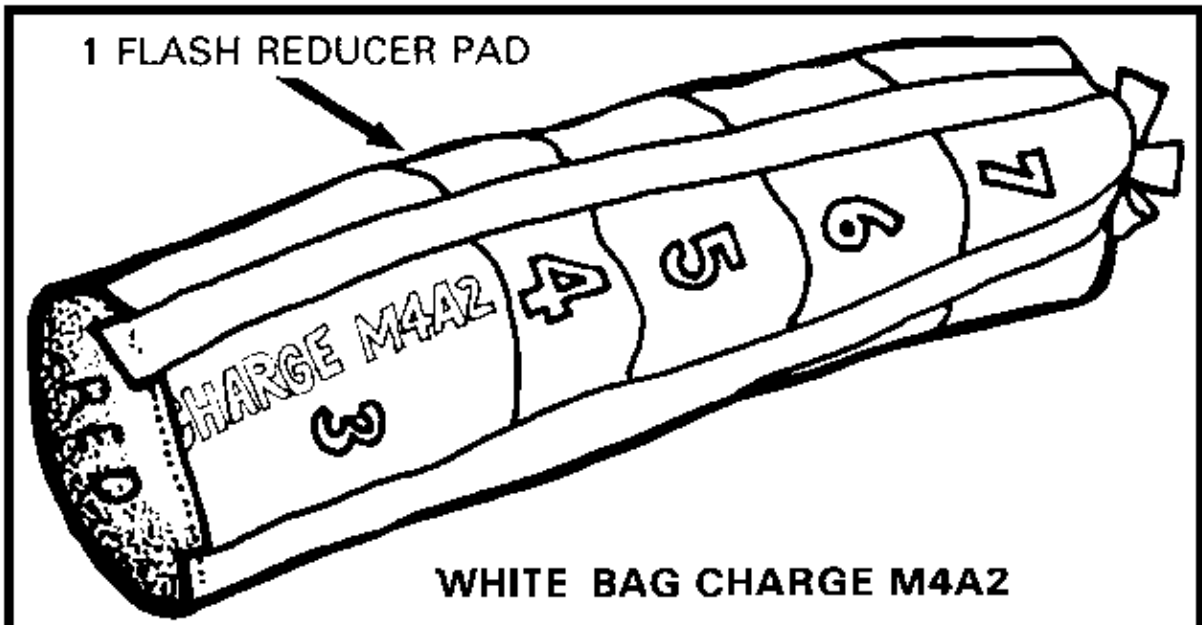

Figure 23. M4A2 propelling charge.

(4) Propelling charge M4A1. Propelling charge M4A1 is identical to the M4A2, except that it does not contain a flash reducer and the base igniter contains black powder. The M2 flash reducer (Figure 26) may be used with this charge and is a separate item of issue.

(5) Propelling charge M119. This is a special single zone (8) charge developed to extend the range of the M109A1 and A3 long tube. This white bag charge consists of only one increment with an igniter bag sewn on the base, and a flash reducer on the front of the charge (Figure 24). Refer to Table 2 to determine which weapon system can use the various propelling charges.

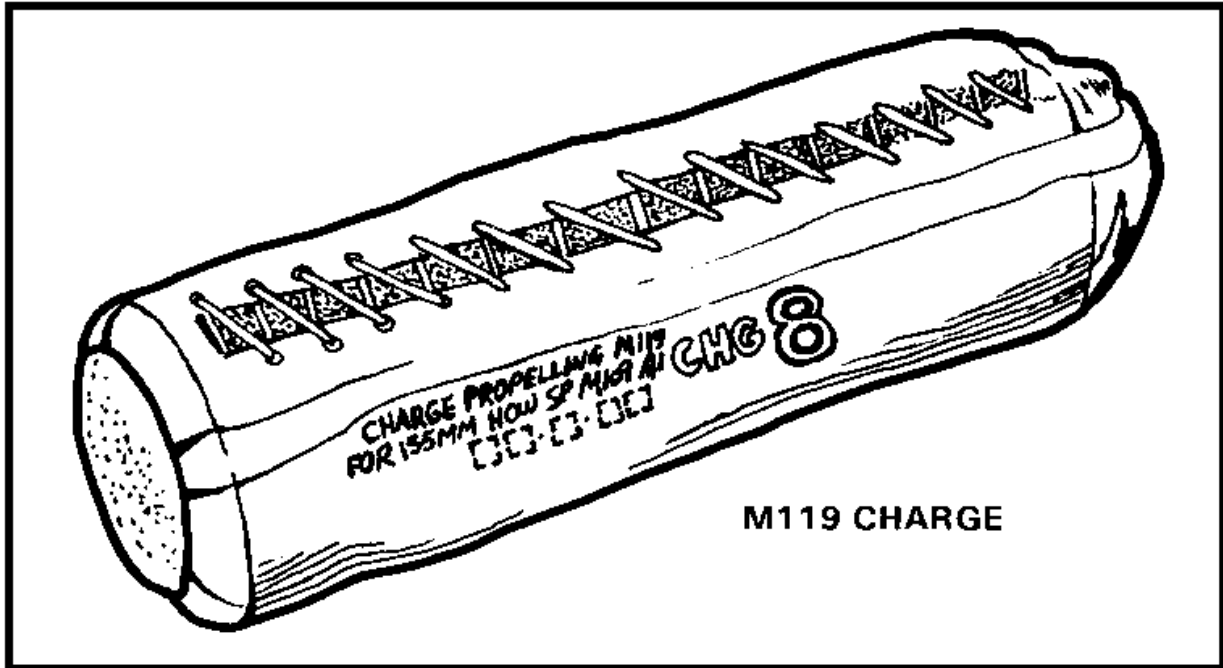

Figure 24. M119 propelling charge.

(6) Propelling charge M119A1. This charge is identical in appearance to the M119 charge. It contains some design improvements that include a modified flash reducer. The modified flash reducer allows firing of the charge with the M549/M549A1 projectile.

(7) Propelling charge M203. The M203 propelling charge is a charge 8(S) propelling charge developed for extended range in long-tube M198 155-mm howitzers. This red bag charge consists of one increment with an igniter bag sewn on its base, a central core igniter extending through the center of the charge, and a flash reducer in front of the charge. The entire length of the charge is encased in a tight-fitting, laced jacket for added strength and stability (Figure 25).



WARNING

WHEN FIRING M203 CHARGE (RED BAG), THE FOLLOWING MUST BE DONE:

- A. DOUBLE EAR PROTECTION MUST BE WORN (EARPLUGS AND HELMETS WITH ACCOUSTICAL MUFFS).
- B. A 25-FOOT (7.50 M) LANYARD MUST BE USED.
- C. NO FIRING ELEVATION CAN BE LESS THAN 270 MILS.
- D. CREW MUST STAND SIDEWAYS TO THE BLAST.
- E. CREW MUST STAND 25 FEET (7.50 M) OR MORE BEHIND THE CANNON.
- F. NO MORE THAN 100 ROUNDS IN A GIVEN 24-HOUR PERIOD CAN BE FIRED BY A CREW OR AN INDIVIDUAL CREW MEMBER.

Figure 25. M203 propelling charge (red bag).

e. Flash reducer M2. The M2 flash reducer consists of a 4-inch square, red cotton cloth bag containing black powder and potassium nitrate (Figure 26). The M2 flash reducer which is a separate item of issue may be used with charges M4, M4A1, or M4A2 if additional flash reduction is desired. In preparing a white bag M4 and M4A1 propelling charge for firing, one flash reducer is added at the forward end of the base charge and at the forward end of each increment used. The flash reducer pads serve to limit muzzle flash and blast overpressure.

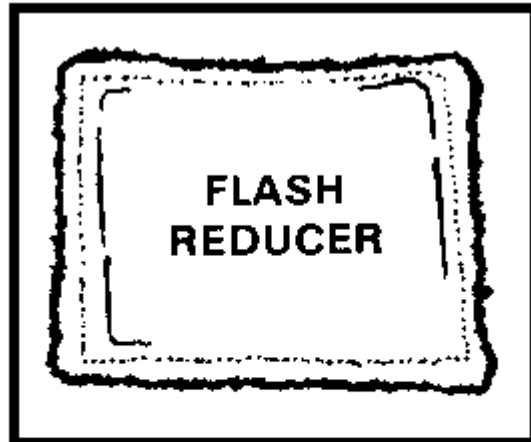

Figure 26. M2 flash reducer.

f. Primers. There is one type of primer used with the 155-mm howitzer.

(1) Primer M82. The M82 primer (Figure 27) is the only authorized primer to be used in the 155-mm, M198 towed, and the 155-mm M109A5/A6 self-propelled howitzers. The primers are ready for firing when unpacked and inspected.

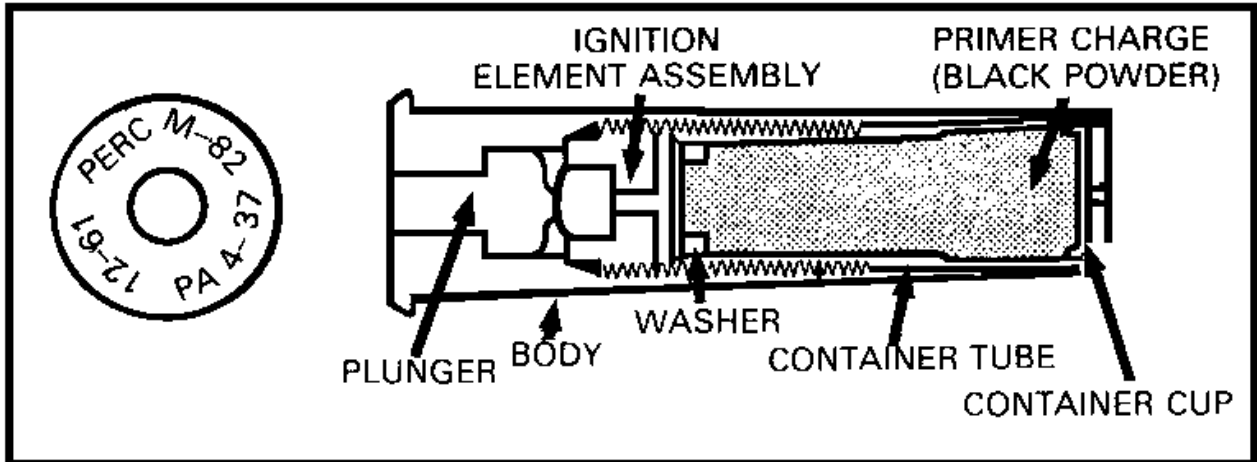

Figure 27. M82 primer.

PRACTICE EXERCISE:

25. Ammunition used in the 155-mm howitzer (both towed and self-propelled) is classified as _____.
26. The M3A1 propelling charge is a green bag charge divided into a base and four increments for firing in zones 1 through _____.
27. The M4A2 propelling charge is used for firing in zones 3 through 7 and consists of a base charge and _____.
28. The M2 flash reducer pad serves to limit blast overpressure and _____.
29. There is only one type of primer available for the 155-mm howitzer cannons. The _____ primer

ANSWERS:

25. separate-loading
26. 5.
27. Four increments.
28. Muzzle flash.
29. M82

11. **PREPARATION FOR FIRING.** Preparation for firing the four components of a complete round of 155-mm ammunition requires efficient teamwork among the cannoneers. They must quickly and accurately select, unpack, inspect, and prepare the correct primer, propellant, projectile, and fuze from the fire commands received by the howitzer section. Certain numbered cannoneers prepare the fuze and projectile, other cannoneers prepare the propellant, and still another cannoneer must insert the primer in the firing lock after the fuzed projectile and propellant have been loaded and the breechblock closed. The chief of section must thoroughly cross train the entire crew so that any crew member can perform any or all of the duties required of any other crew member.

a. M82 primers. Primers are ready for firing when removed from packing and need only be inserted into the firing lock of the weapon. These primers are packed one per waterproof bag. Do not open this protective bag until ready to use the primer.

b. Propellant. Propelling charges come packed in hermetically sealed metal containers. There is one complete charge in each container of the M4 series, M119-series white bag (WB), and M203 charges. The M3-series green bag (GB) charges are packed with two complete charges in each metal container. A cannoner will unpack, inspect, and prepare the designated propelling charge. Some of the things to look for when preparing the propellant for firing are as follows:

(1) Select the right charge announced in the fire command.

(2) Unpack the charge from the metal container and inspect the charge for torn cloth, loose powder grains, or discoloration of the cloth bags.

(3) Remove the igniter cap, and inspect the red igniter pad. The pad should not be torn or wet. The igniter powder grains are highly hygroscopic (will absorb moisture), and moisture will cause the grains to stick together, which could cause misfires. The igniter powder grains should move freely inside the pad to show that they are not stuck together.

(4) Check the smell of the powder charge and its container. The smell should not be a sour, acid smell (indicates the charge got wet), but a sweet, ether-like smell showing that it is a fresh charge that has been protected from moisture by its hermetically sealed metal container.

(5) Remove any excess powder increments (those increments with a higher number than called for in the fire command), and retighten the tie straps so that all powder increments are secure with the highest numbered increment on top.

(6) Place the unused powder increments in a secure container. Under the supervision of an officer, dispose of the unused powder later by burning.

c. Projectile. Projectiles for these howitzers (M198, M109A5/A6) normally come packed eight to a pallet, with the top and bottom of the wooden pallet banded together. Each projectile has an eyebolt lifting plug and a grommet attached for protection during shipping and handling activities (except the M712 Copperhead, which comes sealed in a clamshell-type container).

When selecting the projectile for firing, observe the following:

(1) Inspect and clean the projectile. Verify that the projectile is the type designated by the fire commands. Remove the grommet, and examine the rotating band to ensure that it is free from all dirt and burrs.

NOTE: A projectile with a burred rotating band will be put aside until the burrs can be removed with a file.

(2) Remove the eyebolt lifting plug and gasket, and examine the fuze well for leaks or damage to the filler. If any high-explosive filler residue clings to the threads of the fuze well, reject the round and get another one.

(3) Examine the entire projectile for defects, and check to see that the projectile is not damaged or corroded and is free of dirt, grease, sand, oil, and so forth.

(4) Hold the projectile upright for fuze setting.

(5) Read and announce the time set on the fuze when directed.

WARNING

BE CAREFUL IN PLACING THE ROUND IN THE HULL TO PREVENT DAMAGE TO THE ROTATING BAND OR FUZE AND BODILY HARM TO THE AMMUNITION HANDLER.

(6) Carry the fuzed projectile to the howitzer, and place it in the hull of the howitzer if self-propelled, or place the projectile on the loading tray (towed) and two cannoneers will carry it to the weapon for loading.

d. Fuzing. Fuzes, fuze wrenches, and fuze setters were discussed in great detail in subcourse FA 3117; however, certain procedures and instructions are discussed below. See Table 8 for fuze setting tools used with authorized fuzes.

WARNING

DO NOT USE THE M549/M549A1 PROJECTILE IF THE LIFTING PLUG HAS BEEN BROKEN. DO NOT TRY TO EXTRACT ANY PORTION OF THE PLUG FROM THE FUZE WELL OF THE PROJECTILE. RETURN THE DEFECTIVE PROJECTILE TO THE AMMUNITION/SUPPLY POINT.

(1) Lifting plug removal.

- Remove the plug, and inspect the filler beneath the plug.
- Inspect the cavity and projectile threads for damage. Remove loose material from the cavity. If any high explosive is found stuck to the threaded portion of the projectile throat, do not fire.

(2) Supplementary charge.

WARNING

DO NOT FIRE CP, PD, MTSQ, OR THE NEW SHORT-INTRUSION VT FUZES IN A DEEP-CAVITY PROJECTILE WITHOUT THE SUPPLEMENTARY CHARGE. IF THE ROUND IS FIRED WITHOUT SUPPLEMENTARY CHARGE, THERE MAY BE AN INBORE PREMATURE EXPLOSION.

WARNING

DO NOT TRY TO REMOVE THE SUPPLEMENTARY CHARGE BY ANY MEANS OTHER THAN THE LIFTING LOOP. USE OF SCREWDRIVERS OR OTHER TOOLS TO REMOVE THE CHARGE BY FORCE IS DANGEROUS.

For the long-intrusion proximity fuze firings, remove the supplementary charge by means of its lifting loop. If the charge cannot be removed by its lifting loop, either fire the round with a short-intrusion VT, PD, or MTSQ fuze or dispose of the round (Figure 28). The supplementary charge must be left in the projectile when short-intrusion fuzes such as the impact mechanical time or M732 VT fuzes (Figure 29 B) are fired. The supplementary charge must be removed when the long-intrusion VT fuzes M728 (Figure 29 C) are fired.

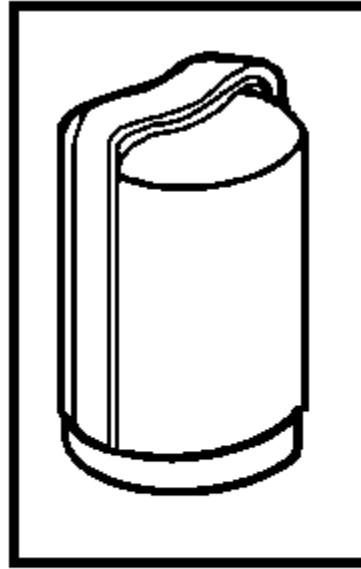

Figure 28. Supplementary charge.

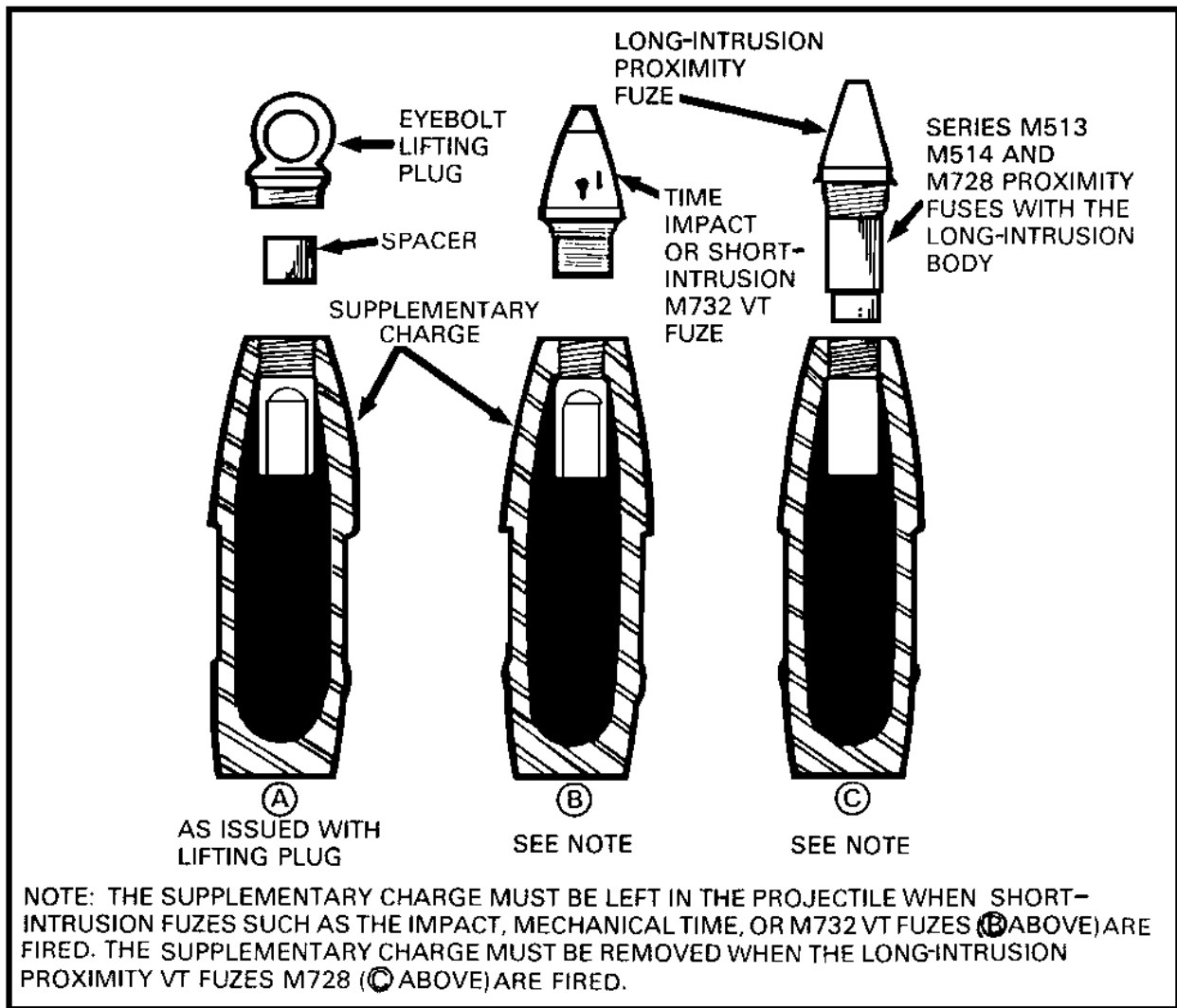

Figure 29. Typical deep-cavity projectiles.

(3) Fuze assembly. The following procedures apply to all fuzes except the M78 CP fuze, which is covered in subparagraph (4).

WARNING

WHEN TIGHTENING THE FUZE TO THE PROJECTILE, DO NOT HAMMER ON THE FUZE WRENCH OR USE THE EXTENSION HANDLE ON THE FUZE WRENCH. NEVER STAKE THE FUZE TO THE PROJECTILE UNDER ANY CIRCUMSTANCES. SHOCKS TRANSMITTED TO FUZES DURING ASSEMBLY MAY CAUSE A MALFUNCTION.

- Screw the fuze in by hand. If binding occurs, inspect the fuze cavity and threads of both fuze and projectile. Reject whichever is at fault.
 - After assembling the fuze by hand, back the fuze off a quarter turn. Using the M18 fuze wrench, tighten the fuze to the projectile with a sharp snap of the wrench so that the fuze shoulder is seated firmly against the projectile nose.
 - If a projectile setscrew is present, tighten it to below the level of the contour of projectile.
- (4) M78 CP fuze. Special preparation for the M78 CP fuze is described below.

- Examine the fuze threads in the projectile and the threads on the M25 booster and M78A1 (or M78) fuze. Do not use components with damaged threads.
- Remove the safety pin from the M25 booster and screw the booster into the booster cavity of the projectile. Tighten the booster firmly with the booster end of the M16 fuze wrench. Boosters that are issued without safety pins should not be used.

NOTE: The booster must always be assembled to the projectile first. It cannot be assembled to the fuze, even though it is shipped in the same fuze container.

- Screw the M78A1 (or M78) fuze into the fuze cavity, and tighten it securely with the fuze end of the M16 fuze wrench. Make sure that the fuze shoulder seats firmly against the projectile. There should be no space between the fuze shoulder and the projectile.

NOTE: For fuze setting procedures for fuzes M739 or M557 PD; M656 MT; M501, M564, M577, and M582 MTSQ; and M514, M728, M732 VT, refer to Subcourse FA 3117.

Table 8. Fuze setting tools.

FUZE								WRENCH OR SETTER
	PD	MT	MTSQ				VT	
M78A1 (CP)	M739 OR M557	M565	M501	M564	M577	M582	M728 M732	
X								M16
	X							M18
			X					M27
						X	X	M27
		X		X				M34
				X	X			M35

e. Loading and firing. The chief of section must ensure that the following duties and actions are done by his cannoneers on every round loaded and fired from his cannon:

- Make sure the round is clean and the fuze is present and fully seated.
- Make sure there are no obstructions in the cannon tube.
- Check the cannon firing lock to see that the primer expended in previous firing has been removed.
- Remove the grommet from the projectile.
- Load the fuzed projectile into the cannon, and ram it firmly into the firing chamber.
- Remove the igniter protective cap from the propelling charge, and load the propelling charge into the cannon chamber with the igniter end (red bag) toward the breech.

WARNING

NEVER CLOSE THE BREECHBLOCK UNLESS YOU CAN SEE THE RED IGNITER PAD ON THE BASE OF THE PROPELLING CHARGE.

- Close and lock the breechblock.

- Insert the primer, and move the firing lock to the firing position. Fires on the command of the chief of section

NOTE: (M114 series) insert the primer into the firing mechanism. A cannoneer places his left hand on the percussion hammer and, with his right hand, inserts the firing mechanism in the housing. He seats the firing mechanism by turning the handle clockwise until it contacts the firing mechanism block handle arm stop and is latched. After the firing mechanism is seated, a cannoneer reaches beneath the breech and attaches the lanyard to the percussion hammer with his right hand. Fires on the command of the chief of section by pulling strongly on the lanyard

f. After firing. After each round is fired, the chief of section will have a member of the crew--

- Verify that the breechblock is opened and secured in the open position.
- Swab the cannon powder chamber with a sponge and water.
- Wipe the face of the obturator spindle, making sure that all burning fragments of the powder charge, if any, are removed from the powder chamber.
- Inspect the cannon tube, and announce BORE CLEAR. If it is not clear, the cannoneer must report the problem to the chief of section immediately.

After the firing has been completed for the day, the chief of section must verify that all ammunition fired has been recorded by charge, number, and type of projectile and that the total number of each round fired for the day has been entered on DA Form 2408-4 (Weapon Record Data).

g. Ammunition prepared for firing but not fired. Using the applicable fuze setter, reset the fuzes on the projectiles prepared for firing but not fired. Disassemble the fuze from the projectile, and repack it in the original packing. When the VT fuze is removed from the projectile, replace the supplementary charge in the projectile before assembling the spacer and lifting plug. Replace the grommet over the rotating band. Restore the propelling charges to their original condition (that is all zones/increments present and tied). Return fuzes, primers, flash reducers, and propelling charges to their original packing containers and seal them to protect the items from moisture.

PRACTICE EXERCISE:

30. Propelling charges for the separate-loading, 155-mm howitzer cannons come packed in--
- a. hermetically sealed wooden boxes.
 - b. hermetically sealed fiberglass containers.
 - c. hermetically sealed metal containers.
 - d. waterproof plastic containers.

31. The M3-series (GB) propellant is packed with how many complete charge(s) in each container?
- a. one
 - b. two
 - c. Three
 - d. Four
32. Projectiles for the 155-mm howitzers normally come packed how many to a pallet?
- a. 4
 - b. 6
 - c. 8
 - d. 10
33. The supplementary charge must be removed when using which VT fuze?
- a. M501
 - b. M514
 - c. M728
 - d. M732

ANSWERS:

- 30. c.
- 31. b.
- 32. c.
- 33. c.

12. MAINTENANCE. Ammunition components are designed and packed to withstand conditions ordinarily encountered in the field. Keep packing boxes and containers from becoming broken or damaged.

WARNING

HANDLE EXPLOSIVE AMMUNITION AND COMPONENTS CONTAINING EXPLOSIVES WITH UTMOST CARE. DO NOT DROP, DRAG, THROW, TUMBLE, OR STRIKE PACKAGED OR UNPACKAGED AMMUNITION OR RELATED COMPONENTS. EXPLOSIVE ELEMENTS IN PRIMERS AND FUZES ARE SENSITIVE TO SHOCK.

a. Protection of ammunition and components. Since ammunition is damaged by moisture, frost, extreme temperatures, and foreign matter (mud, oil, grease, and so forth)--

- Do not break the moisture-resistant seal on the container until the ammunition is to be used.
- Shield the ammunition, particularly fuzes and propelling charges, from sources of high temperature (direct rays of the sun).
- Protect fuzes, primers, and flash reducers at all times from foreign matter and impact.

CAUTION

A DROP OF ONLY 4 FEET MAY CAUSE THE ELECTROLYTE VIAL IN A VT FUZE BATTERY TO BREAK. THUS CREATING A DUD WHEN USED IN A PROJECTILE.

b. Unpacking ammunition. When unpacking ammunition components at the firing position, be sure to retain the packing material and containers for repacking components not fired. Lot numbers and nomenclature on the packing material and containers must agree with the items being repacked. Do not mix lot numbers or components.

c. Maintenance inspection. Inspect ammunition packaging daily. Open boxes or containers that show evidence of contamination or deterioration, and inspect ammunition. Do not open sealed boxes or containers unless defective ammunition is suspected. Following are procedures used while inspecting ammunition:

- Inspect unpackaged ammunition and explosive components daily.
- Wipe dry and clean wet or dirty ammunition at once. Remove light corrosion, but do not polish ammunition to make it look better.
- Consider ammunition that exhibits severe rust or propellant contamination, particularly moisture, as unserviceable. Do not use this ammunition, except in emergencies, and turn in such ammunition to the ammunition supply point (ASP) as soon as possible.
- When repackaging ammunition, replace it in its original containers. If other packing material must be used, the current markings must be transferred to the new containers.

(1) Projectiles. Visually inspect projectiles for the following defects:

- Distorted or damaged body.
- Dirt or other material.
- Exudation (oozing out) of explosive filler.
- Rust through the projectile base plate.

(2) Propelling charge M3 and M4 series. Visually inspect these propelling charges for the following defects:

- Loose tie straps, allowing separation of the charge into increments.
- Missing increment, extra increment, or incorrect sequencing (order) of increments.
- Increment bags torn or damaged to the extent that black powder or propellant spills out.
- Wet propelling charge.
- Missing or damaged red igniter pad on base of the charge.

Charges requiring retying are retied by assembling the increments in correct order and then tying the four straps over the top of the charge tightly.

(3) Propelling charges M102, M119, M119A1, M119A2, M109A5, M109A6. Visually inspect these propelling charges for the following defects:

- Missing flash reducer.
- Charge bag ripped or damaged to the extent that propellant can spill.

- Black powder leaking from the base igniter pad.
- Base igniter pad not centered with respect to the outer diameter of charge.
- Evidence of a broken or damaged center igniter tube (M119, M119A1 only).
- Tie straps not tight over forward end of charge.
- Lacing jacket not secure on charge (M119, M119A1, only).
- Cord missing or broken on lacing jacket (M119, M119A1, only).

If tie straps are loose, retighten by undoing the knots and retying the straps over the flash reducer at the forward end of the charge, using two interlocking square knots. Return all defective charges to the ASP.

d. Reassembly of propelling charges prepared but not fired. Reassemble propelling charges prepared for firing and not used and replace them in their original containers as follows:

- If an increment was removed, reinstall and retie as indicated in paragraph 13c above.
- Replace igniter protective cap.
- Repack charge in the container (igniter end first); close and secure container.
- Mark the container appropriately and use the charge first in subsequent firings.

e. Unserviceable ammunition components.

(1) Conspicuously mark unserviceable ammunition or explosive components UNSERVICEABLE and return them to the ammunition supply personnel for disposition. All layers of packing must be conspicuously marked UNSERVICEABLE.

(2) Repackage ammunition components in the original containers. If the original container is unsuitable, use any available package material and transfer all markings.

PRACTICE EXERCISE:

34. T F A drop of only 4 feet may cause the electrolyte vial in a VT fuze battery to break.
35. T F When unpacking ammunition components at the firing position, there is no need to retain the packing material and containers for repacking components not fired.
36. T F Black powder leaking from the base igniter pad should be turned in to the ammunition supply point (ASP) as defective.
37. T F Ammunition components prepared for firing but not fired should be repackaged in their original containers.

ANSWERS:

34. T
 35. F
 36. T
 37. T

13. MISFIRE, SAFETY PROCEDURES.

a. General definitions. To avoid injury to personnel and damage to equipment, it is important that all concerned personnel understand the following:

- Check firing. CHECK FIRE is a command normally given by the executive officer. But, in an emergency, it may be given by anyone present. Usually, check firing is given if an unsafe act is observed. This command will cause an immediate halt in firing.

- Cold tube. Any tube that has or has not exceeded the prescribed rates of fire and does not cause water from a wet swab to boil, fry, or steam off when placed just forward of the gas check seat.

- Hot tube. Any tube that has or has not exceeded the prescribed rate of fire and causes water from a wet swab to boil, fry, or steam off when placed just forward of the gas check seat.

- Cook off. A cook off is the functioning of the propelling charge when initiated by the heat of the weapon.

- Hang fire. A hang fire is a delay in the functioning of the primer, igniter, or propelling charge. This delay, though unpredictable, ranges from a fraction of a second to 10 minutes.

- Misfire. A misfire occurs when the weapon does not fire after an attempt to fire has been made. This may be because the primer, igniter, propelling charge, or firing mechanism fails to function wholly or in part. A misfire in itself is not dangerous. However, it cannot be immediately distinguished from a hang fire; therefore, misfires must be treated as hang fires.

- Sticker. A sticker is a projectile that is lodged in the tube after normal functioning of the ignition train. When stickers occur, gases under high pressure are retained in the chamber.

b. Hot tube loading precautions. Certain precautions must be taken when artillery ammunition is being fired from a hot tube; therefore, the officer in charge of firing must determine when the tube is hot enough for the procedures and precautions to be applicable. Several factors that may cause a hot tube situation to exist are the ambient temperature, the temperature of the ammunition, the rate of fire within a specific period, and the charge being fired. The person in charge of firing must determine whether a hot tube situation exists and, if so, observe the following precautions:

- (1) Never chamber a round in the tube until immediately before firing.

- (2) Within 5 minutes, either fire or remove from the weapon a round that has been chambered in a hot tube.

- (3) If a round in a hot tube cannot be fired or removed within 5 minutes after being loaded and a misfire is not involved, take the following actions:

- Remove the primer and propelling charge immediately.

- Evacuate all personnel to a safe distance.

- Keep the weapon laid on safe data.

- Notify EOD for projectile removal.

c. Misfire procedures for 155-mm weapons firing separate-loading ammunition, cold tube. After a failure to fire, actuate the firing mechanism two additional times in an attempt to fire. If the weapon still fails to fire, wait 2 minutes from the last attempt to fire and then remove and inspect the primer.

(1) If the primer is not dented, the fault is in the firing mechanism. Repair or replace the firing mechanism, replace the primer, and then fire the weapon.

(2) If the primer is dented, the primer may be at fault. Replace the primer with another and then fire the weapon.

(3) If the primer fired, the fault may be with the propelling charge. Wait 10 minutes (8 minutes after removal and inspection of the primer), and open the breech and remove the propelling charge for disposal as defective. Reload the weapon with a new propelling charge and primer for firing.

NOTE: Check the propelling charge. It may have been inserted incorrectly, the igniter pad could be wet, or the primer vent hole may be plugged.

d. Misfire procedures for 155-mm weapons firing separate-loading ammunition, hot tube. After a failure to fire on activation of the firing mechanism, actuate the firing mechanism two additional times in an attempt to fire. If the weapon still fails to fire, wait 2 minutes from the last attempt to fire, remove and inspect the primer, and follow one of the two safety procedures below.

(1) If the primer has fired, evacuate all personnel to a safe distance, and follow the safety procedures and precautions presented in paragraph 132b (3) above.

NOTE: In a combat emergency, if the primer has fired, insert a new primer and try to fire the weapon. If the weapon still fails to fire, follow the procedures in paragraph 13b (3).

(2) If the primer has not fired, insert a new primer or correct the faulty firing mechanism and try to fire the weapon. If the weapon cannot be fired within 3 additional minutes (total of 5 minutes from the time the round was chambered in the weapon), remove the propelling charge and follow the safety procedures and precautions in paragraphs 13b(1) through (3).

PRACTICE EXERCISE:

38. a cook off is the functioning of the _____ initiated by the heat of the weapon.

39. In a misfire procedure (cold tube) if the primer has fired, the fault may be in the _____.

40. In a misfire procedure (cold tube) if the primer is not dented, the fault may be in the _____.

41. After a failure to fire (hot tube) on activation of the firing mechanism, activate the firing mechanism _____ additional times in an attempt to fire.

ANSWERS:

38. Propelling charge

39. Propelling charge.

40. Firing mechanism.

41. Two

14. SUMMARY.

a. The major components of the 155-mm howitzer, towed, are the carriage, the barrel and breech assemblies, the recoil mechanism, and the sighting and laying equipment.

b. The 155-mm M114/M114A1/M114A2 and M198 towed howitzers are medium artillery weapons designed to provide either general support or direct support. The prime mover is the 5-ton truck.

c. The 155-mm howitzer, M109A1/A2/A3 self-propelled is a medium howitzer that is highly mobile and air transportable.

d. Ammunition for the 155-mm howitzer cannons is classified as separate-loading. That is, the loading of each complete round requires three separate operations. These operations are loading the fuzed projectile, then the propelling charge, and finally the primer.

e. There are two different models of primers used in the 155-mm howitzer, the MK2A4 and M82. The MK2A4 is used in the M114 series, and the M82 is used in all other 155-mm weapons. Be sure you know which primer is authorized for what weapon.

f. The three malfunctions that can occur in the firing of cannon ammunition are a misfire, hang fire, and cook off. Be sure to learn the exact procedures to use when these conditions exist.